



TECHNICAL SERVICE BULLETIN

Harsh/Delayed Engagement And/Or Harsh/Delayed Shift

25-2134
16 April 2025

This bulletin supersedes 25-2024. Reason for update: update the Part List and Service Procedure

Model:

Ford 2019-2023 Ranger	Built on or before 15-Aug-2022
--------------------------	--------------------------------

Markets: North American markets only

Issue: Some of the vehicles listed in the Model statement above may exhibit at least one of the following conditions:

- Harsh engagement
- Delayed engagement
- Harsh shift
- Delayed shift
- Illuminated MIL with DTC P0751, P0752, P0756, P0757, P0761, P0762, P0766, P0767, P0771, P0772, P2700, P2701, P2702, P2703, P2704, P2705, P2707, P2708, P0729, P0731, P0732, P0733, P0734, P0735, P0736, P076F, P07D9, P07F6 and/or P07F7 stored in the PCM.

This may be due to axial movement of the CDF clutch cylinder sleeve causing hydraulic circuit leaks.

NOTE: If internal transmission service is required to address a concern detected with the CDF clutch cylinder following this article, technicians should carefully inspect and replace other transmission components and flush transmission fluid cooler only as necessary to confirm proper function. Add a new line to the repair order to document any additional repairs needed. M-time can be claimed on the additional repair line to cover labor. Refer to Warranty and Policy Manual for additional information. A thorough understanding of transmission description and operation will assist the technician with proper diagnosis, inspection, and successful repair of the customer concern.

NOTE: The Pressure Vacuum Transducer (PVT) Kit (Rotunda 164-R9833) and VCMM Transmission Extension Kit (Rotunda 164-R9534) recommended to perform this article are no longer included with the VCMM Advanced Kit (Rotunda 164-R9823) since July 2023. Supply of the PVT Kit (Rotunda 164-R9833) and VCMM Transmission Extension Kit (Rotunda 164-R9534) have been sold out. Ford has confirmed a high percentage (80%) of Dealers have this equipment available. Alternatively, Ford has tested suitable transmission fluid pressure gauges and developed procedures which reliably enable the capability to perform this article. Refer to Table 1 in the Service Procedure. In addition, VCMM Universal Probe Tip Adapter (Rotunda 164-R9834, or equivalent) is needed to perform this article. The Probe Tip Adapters are included in VCMM Advanced Kit (Rotunda 164-R9823).

Action: For vehicles that meet all of the criteria in the Issue and Model statements, follow the Service Procedure to verify hydraulic circuit leakage and, if instructed, replace the CDF clutch cylinder and the clutch and planetary container cylinder.

Parts - CDF Cylinder Replacement

Service Part Number	Claim Quantity	Package Order Quantity	Number in Package	Description
HL3Z-7G199-A	1	1	1	Auxiliary Pump Tube Seal (If Equipped)

HL3Z-7A248-A	1	1	1	Torque Converter Seal
JL3Z-7N134-A	12	12	1	Front Support Bolts
LC3Z-7H223-A	12	12	1	Front Support Bolt Seals
HL3Z-7A248-G	1	1	1	Front Support To Case Seal
HL3Z-7G091-F	5	5	1	Input Shaft Seals (F2)
HL3Z-7B399-C	4	4	1	Sun Gear No. 3 Shaft Seals (F7)
HL3Z-7C099-A	1	1	1	C Clutch Balance Dam Inner Seal
HL3Z-7A548-B	2	2	1	C Clutch Balance Dam And Piston Outer Seal
HL3Z-7D404-A	2	2	1	C And D Clutch Piston Inner Seals
HL3Z-7A262-C	1	1	1	D Clutch Balance Dam
HL3Z-7D403-A	1	1	1	D Clutch Piston Outer Seal
HL3Z-7A548-G	2	2	1	F Clutch Balance Dam And Piston Outer Seal
HL3Z-7A548-A	2	2	1	F Clutch Balance Dam And Piston Inner Seal
HL3Z-7G091-G	5	5	1	Input Shaft To Sun Gear No. 3 Shaft Seals (F8)
HL3Z-7G091-C	1	1	1	Input Shaft Seal (F9)
JR3Z-7H351-B	1	1	1	CDF Cylinder
PC3Z-7B177-A	1	1	1	Clutch And Planetary Container Cylinder

Parts - CDF Cylinder Replacement - Parts To Inspect And Replace Only If Necessary

Service Part Number	Claim Quantity	Package Order Quantity	Number in Package	Description
HL3Z-7A191-B	Only If Necessary (1 Possible)	Only If Necessary (1 Possible)	1	Fluid Pan Gasket
HL3Z-7A098-A	Only If Necessary (1 Possible)	Only If Necessary (1 Possible)	1	Fluid Filter
7T4Z-7Z302-A	Only If Necessary (1 Possible)	Only If Necessary (1 Possible)	1	Transmission Fluid Filter Seal
HL3Z-7J227-A	Only If Necessary (1 Possible)	Only If Necessary (1 Possible)	1	Auxiliary Pump Tube O-ring (If Equipped)
HL3Z-7B066-AB	Only If Necessary (1 Possible)	Only If Necessary (1 Possible)	1	A Pressure Plate
HL3Z-7B164-E	Only If Necessary (3 Possible)	Only If Necessary (3 Possible)	1	A Clutch Friction Plates
HL3Z-7F220-A	Only If Necessary (2 Possible)	Only If Necessary (2 Possible)	1	A Clutch Steel Plates
HL3Z-7B442-F	Only If Necessary (4 Possible)	Only If Necessary (4 Possible)	1	C Clutch Steel Plates
HL3Z-7B164-A	Only If Necessary (4 Possible)	Only If Necessary (4 Possible)	1	C Clutch Friction Plates

ML3Z-7B477-A	Only If Necessary (1 Possible)	Only If Necessary (1 Possible)	1	C Clutch Pressure Plate
HL3Z-7B442-D	Only If Necessary (5 Possible)	Only If Necessary (5 Possible)	1	D Clutch Steel Plates
HL3Z-7B164-C	Only If Necessary (5 Possible)	Only If Necessary (5 Possible)	1	D Clutch Friction Plates
HL3Z-7B066-E	Only If Necessary (1 Possible)	Only If Necessary (1 Possible)	1	D Clutch Pressure Plate
HL3Z-7B164-G	Only If Necessary (3 Possible)	Only If Necessary (3 Possible)	1	F Clutch Steel Plates
HL3Z-7B164-D	Only If Necessary (3 Possible)	Only If Necessary (3 Possible)	1	F Clutch Friction Plates
HL3Z-7B066-A	Only If Necessary (1 Possible)	Only If Necessary (1 Possible)	1	F Clutch Pressure Plate

Parts - All Vehicles - CDF Cylinder Replacement - Select One Of The Following If Needed

Service Part Number	Claim Quantity	Package Order Quantity	Number in Package	Description
HL3Z-7B066-AA	Only If Necessary	Only If Necessary	1	A Clutch Apply Plate 4.1 - 4.3 mm Selective
HL3Z-7B066-Z	Only If Necessary	Only If Necessary	1	A Clutch Apply Plate 4.4 - 4.6 mm Selective
HL3Z-7B066-Y	Only If Necessary	Only If Necessary	1	A Clutch Apply Plate 4.7 - 4.9 mm Selective
HL3Z-7B066-X	Only If Necessary	Only If Necessary	1	A Clutch Apply Plate 5.0 - 5.2 mm Selective
HL3Z-7B066-W	Only If Necessary	Only If Necessary	1	A Clutch Apply Plate 5.3 - 5.5 mm Selective
HL3Z-7H032-C	Only If Necessary	Only If Necessary	1	T-3 Bearing (Replace If T-3 Shim Is Replaced)
HL3Z-7A527-Q	Only If Necessary	Only If Necessary	1	T-3 Shim 3.05-3.15 mm Selective
HL3Z-7A527-P	Only If Necessary	Only If Necessary	1	T-3 Shim 3.2-3.3 mm Selective
HL3Z-7A527-R	Only If Necessary	Only If Necessary	1	T-3 Shim 3.35-3.45 mm Selective
HL3Z-7A527-K	Only If Necessary	Only If Necessary	1	T-3 Shim 3.5-3.6 mm Selective
HL3Z-7A527-L	Only If Necessary	Only If Necessary	1	T-3 Shim 3.65-3.75 mm Selective
HL3Z-7A527-M	Only If Necessary	Only If Necessary	1	T-3 Shim 3.8-3.9 mm Selective
HL3Z-7A527-S	Only If Necessary	Only If Necessary	1	T-3 Shim 3.95-4.05 mm Selective
HL3Z-7A527-T	Only If Necessary	Only If Necessary	1	T-3 Shim 4.1-4.2 mm Selective
HL3Z-7A527-N	Only If Necessary	Only If Necessary	1	T-3 Shim 4.25-4.35 mm Selective

HL3Z-7D483-A	Only If Necessary	Only If Necessary	1	D Clutch Snap Ring 1.8 mm Selective
HL3Z-7D483-B	Only If Necessary	Only If Necessary	1	D Clutch Snap Ring 2.0 mm Selective
HL3Z-7D483-C	Only If Necessary	Only If Necessary	1	D Clutch Snap Ring 2.2 mm Selective
HL3Z-7D483-D	Only If Necessary	Only If Necessary	1	D Clutch Snap Ring 2.4 mm Selective
HL3Z-7D483-E	Only If Necessary	Only If Necessary	1	D Clutch Snap Ring 2.6 mm Selective
HL3Z-7D483-F	Only If Necessary	Only If Necessary	1	D Clutch Snap Ring 2.8 mm Selective
HL3Z-7C122-A	Only If Necessary	Only If Necessary	1	C Clutch Snap Ring 1.5 mm Selective
HL3Z-7C122-B	Only If Necessary	Only If Necessary	1	C Clutch Snap Ring 1.7 mm Selective
HL3Z-7C122-C	Only If Necessary	Only If Necessary	1	C Clutch Snap Ring 1.9 mm Selective
HL3Z-7C122-D	Only If Necessary	Only If Necessary	1	C Clutch Snap Ring 2.1 mm Selective
HL3Z-7C122-E	Only If Necessary	Only If Necessary	1	C Clutch Snap Ring 2.3 mm Selective
HL3Z-7C122-F	Only If Necessary	Only If Necessary	1	C Clutch Snap Ring 2.5 mm Selective
HL3Z-7H365-C	Only If Necessary	Only If Necessary	1	F Clutch Snap Ring 1.5 mm Selective
HL3Z-7H365-D	Only If Necessary	Only If Necessary	1	F Clutch Snap Ring 1.7 mm Selective
HL3Z-7H365-E	Only If Necessary	Only If Necessary	1	F Clutch Snap Ring 1.9 mm Selective
HL3Z-7H365-F	Only If Necessary	Only If Necessary	1	F Clutch Snap Ring 2.1 mm Selective
HL3Z-7H365-G	Only If Necessary	Only If Necessary	1	F Clutch Snap Ring 2.3 mm Selective

Parts - Transmission Removal And Installation

Service Part Number	Claim Quantity	Package Order Quantity	Number in Package	Description	Note
JB3Z-4B496-B	6	6	1	CV Joint-To-Transfer Case And Pinion Flange Bolts And Retaining Straps (4WD)	
BE8Z-6731-AB	1	1	1	Engine Oil Filter And Gasket (4WD)	
KB3Z-6L612-A	1	1	1	Catalytic Converter Gasket	
W500121-S437	9	3	4	Transfer Case Bolts (4WD)	
W500642-S437	4	4	1	Transmission Support Insulator Bolts (4WD)	

W700056-S450B	2	1	4	Selector Lever Cable Bracket Bolts	
W714265-S442	3	1	4	Catalytic Converter Nuts	
W715618-S437	6	2	4	Torque Converter Nuts	
W716936-S442	2	2	1	Stabilizer Bar Bracket Nuts	
W719427-S439	2	1	4	Stabilizer Bar Bracket Bolts	
W710233-S437	4	4	1	Driveshaft Flange To Pinion Flange Bolts	
W714780-S439	2	1	4	Driveshaft Center Bearing Bolt (If Equipped With Two Piece Driveshaft)	
W716344-S437	4	4	1	Driveshaft Flange To Transmission Flange Bolts	
PM-4-A	As Needed	As Needed		Motorcraft® Brake Parts Cleaner - VOC Compliant (All Markets Except Canada)	
PM-4-B	As Needed	As Needed		Motorcraft® Metal Brake Parts Cleaner (Not Compliant With Low Volatile Organic Compound Requirements) (All Markets Except Canada)	
CPM-4-A	As Needed	As Needed		Motorcraft® Brake Parts Cleaner - VOC Compliant (Canada Only)	
XL-2	As Needed	As Needed		Motorcraft® High Temperature Nickel Anti-Seize Lubricant	
XL-5-A	As Needed	As Needed		Motorcraft® Multi-Purpose Grease Spray	
XO-5W30-Q1SP	As Needed	As Needed		Motorcraft® SAE 5W-30 Synthetic Blend Motor Oil (All Markets Except Canada)	
CXO-5W30-LSP6	As Needed	As Needed		Motorcraft® SAE 5W-30 Super Premium Motor Oil (Canada Only)	
XT-10-QLVC	As Needed	As Needed		Motorcraft® MERCON® LV Automatic Transmission Fluid (4WD) (All Markets Except Canada)	Transfer Case
CXT-10-LV6	As Needed	As Needed		Motorcraft® MERCON® LV Automatic Transmission Fluid (4WD) (Canada Only)	Transfer Case
XT-12-QULV	As Needed	As Needed		Motorcraft® MERCON® ULV Automatic Transmission Fluid	

Parts

Service Part Number	Claim Quantity	Package Order Quantity	Number in Package	Description
JB3Z-7J227-A	Only If Necessary (4 Possible)	Only If Necessary (4 Possible)	1	Transmission Fluid Cooler Tube Seals
W701183-S1300	Only If Necessary (2 Possible)	Only If Necessary (1 Possible)	4	Engine Block Dowel Pins

Service part numbers and "number in package" quantity may change after publication, thus also affecting the

"package order quantity". Refer to the parts catalog for the latest information.

Claim Quantity refers to the total number of individual pieces required to repair the vehicle.

Package Order Quantity refers to the amount of the service part number package(s) required to repair the vehicle.

Number In Package refers to the number of individual pieces included in a service part number package.

As Needed indicates the part is necessary but amount of the part may vary and/or is not a whole number. Parts can be billed out as non-whole numbers, including less than 1.

Only If Necessary indicates the part is not mandatory. Refer to the Service Procedure to determine the inspection/inclusion criteria.

Warranty Status: Eligible under provisions of New Vehicle Limited Warranty (NVLW)/Service Part Warranty (SPW)/Service Part New Vehicle (SPNV)/Extended Service Plan (ESP) coverage. Limits/policies/prior approvals are not altered by a TSB. NVLW/SPW/SPNV/ESP coverage limits are determined by the identified causal part and verified using the OASIS part coverage tool.

Labor Times

Description	Operation No.	Time
2019-2023 Ranger 4X2/4X4: Follow The Service Procedure To Verify Hydraulic Circuit Leakage (Pass) (Do Not Use With Any Other Labor Operations)	252134A	1.0 Hrs.
2019-2023 Ranger 4X2: Follow The Service Procedure To Verify Hydraulic Circuit Leakage (Fail) Replace The CDF Clutch Cylinder (Do Not Use With Any Other Labor Operations)	252134B	12.6 Hrs.
2019-2023 Ranger 4X4: Follow The Service Procedure To Verify Hydraulic Circuit Leakage (Fail) Replace The CDF Clutch Cylinder (Do Not Use With Any Other Labor Operations)	252134C	13.7 Hrs.

Repair/Claim Coding

Causal Part:	7H351
Condition Code:	42

Service Procedure

Ranger fitting installation



How to back probe

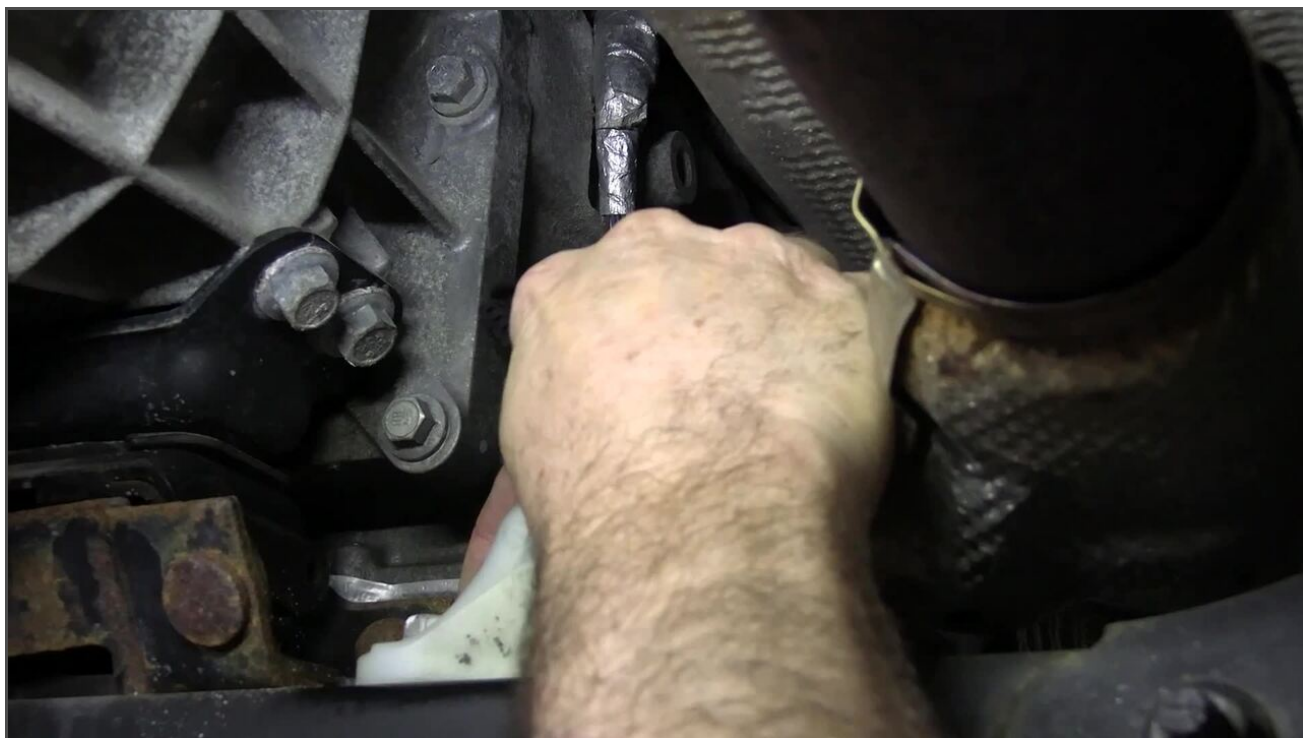

1. Is a VCMM PVT available?

- (1). Yes - proceed to "Diagnostic Procedure A - VCMM PVT Is Available".
- (2). No - proceed to "Diagnostic Procedure B - No VCMM PVT Available".

Diagnostic Procedure A - VCMM PVT Is Available

1. Install the VCMM PVT to the transmission line pressure port. (Figure 1)

Figure 1

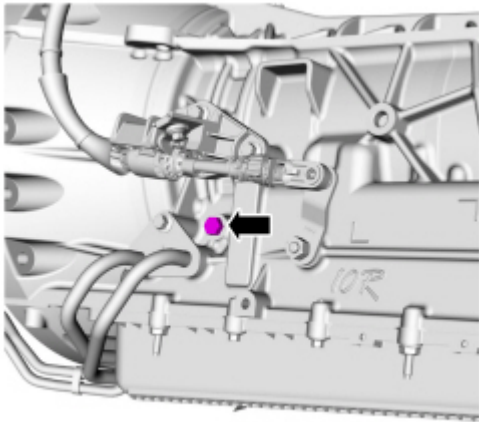

E240432

NOTE: Using the necessary adapter fittings shown in (Figure 2) the PVT can be installed without removing the transmission fluid cooler and bracket.

NOTE: The line pressure port is an M10X1.0 thread. Do not use a National Pipe Thread (NPT) fitting when installing pressure reading equipment. If an NPT fitting is used, damage to the transmission case will occur.

NOTE: The transmission extension hose kit requires a 1/4 in. Joint Industry Council (JIC) male adapter.

NOTE: All NPT fittings must be assembled with polytetrafluoroethylene (PTFE) tape or paste to prevent leaks.

- VCMM Transmission Extension Kit
- Locally obtain the necessary adapter fittings to connect the VCMM PVT pressure transducer to the transmission line pressure port (Figure 2)

Figure 2

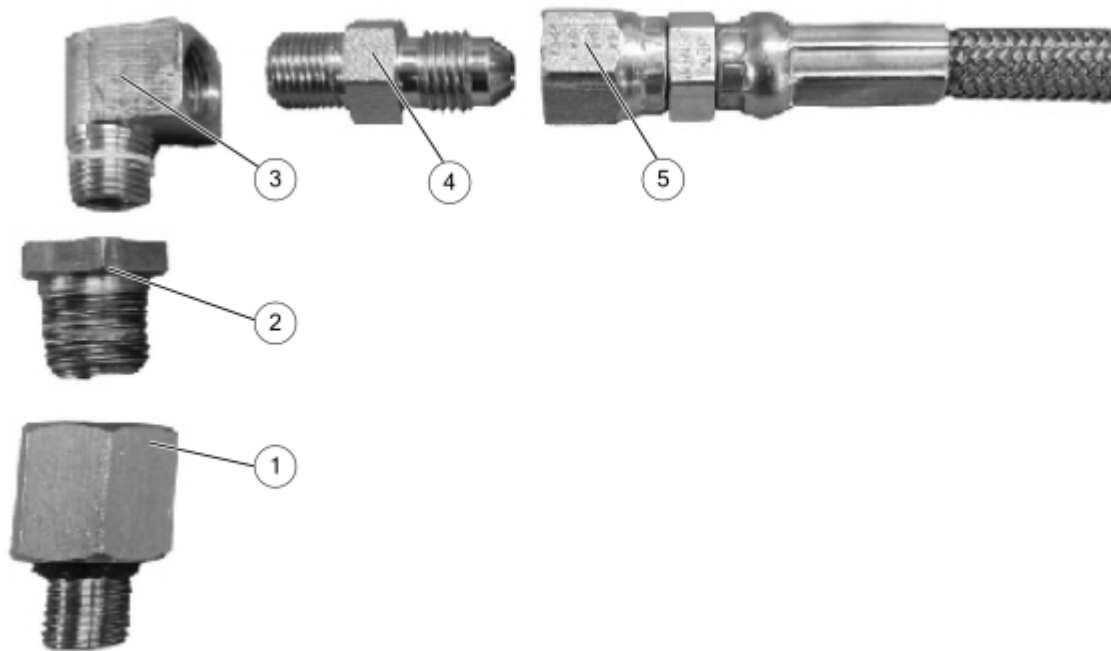

E445306

Item	Description
1	M10X1.0 male to 1/4 in. NPT female
2	1/4 in. NPT male to 1/8 in, NPT female
3	1/8 in, NPT male to 1/8 in, NPT female 90 degree elbow
4	1/8 in, NPT male to 1/4 in> JIC male
5	Extension hose

2. Prepare the transmission LPC solenoid circuit CET50 to be back probed at the transmission electrical connector by removing the connector cover. Access to the LPC solenoid circuit CET50, WH-OG wire is required in a later step. Refer to Wiring, Cell 030 Transmission Controls and the video link at the start of the Service Procedure in this article.

NOTE: Back probing the LPC solenoid circuit will set a DTC and illuminate the powertrain malfunction (wrench) indicator.

3. Using the latest software level of the FDRS and VCMM, start a session.

4. Does the vehicle exhibit harsh/delayed engagement and/or harsh/delayed shift symptoms only when TFT is at 49°C (121°F) or below?

(1). Yes - when prompted in Step 5, choose the FDRS option for the transmission shift concern occurs when the TFT is at or below 49°C (121°F).

(2). No - when prompted in Step 5, choose the FDRS option for the transmission shift concern occurs when the TFT is at or above 50°C (122°F).

5. Select and run the FDRS Transmission Clutch Circuit Leak Test, follow FDRS screen prompts and directions to proceed.

- When prompted, choose the transmission fluid temperature identified in Step 4.
- When prompted, ground the LPC circuit using a VCMM Universal Probe Tip Adapter (Rotunda 164-R9834, or

equivalent) along with a suitable multimeter lead wire and probe (Figure 3) to back probe and ground the LPC solenoid circuit CET50. (Figure 4) Once line pressure has elevated and stabilized, the ground probe is no longer needed to maintain elevated line pressure.

Figure 3



E445307

Item	Description
1	VCMM universal probe adapter
2	Multimeter lead wire
3	Multimeter lead wire probe

Figure 4 - Back probing a PCM connector, other connectors are similar

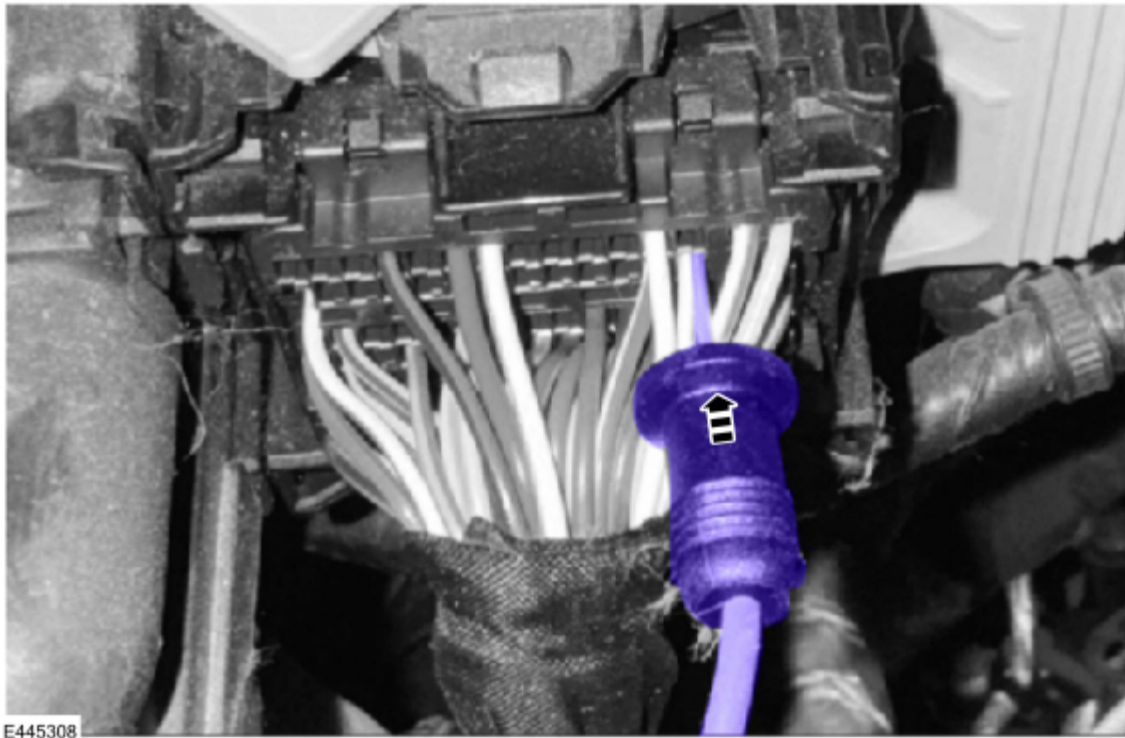

E445308

6. Test is complete. Release control of all parameters then turn ignition off.
 - (1). Remove back probe from the LPC circuit connector and reinstall the connector cover.
 - (2). Turn ignition on (KOEO) and clear all CMDTCs.
 - (3). Turn ignition off.
7. Did the transmission test results pass?
 - (1). Yes - this article does not apply. Refer to WSM, Section 307-01 for normal diagnostics.
 - (2). No - (field displays red) - proceed to "Repair Procedure" In this article.

Diagnostic Procedure B - No VCMM PVT Available

1. Install a suitable transmission fluid pressure gauge that measures at least 300 PSI (2,000 kPa) with vibration dampening to the line pressure port. (Figure 1) Refer to Table 1.

NOTE: Using similar adapter fittings as shown in (Figure 2) install a suitable transmission fluid pressure gauge without removing the transmission fluid cooler and bracket.

NOTE: The line pressure port is an M10X1.0 thread. Do not use a National Pipe Thread (NPT) fitting when installing pressure reading equipment. If an NPT fitting is used, damage to the transmission case will occur.

NOTE: All NPT fittings must be assembled with polytetrafluoroethylene (PTFE) tape or paste to prevent leaks.

Table 1 - Ford tested suitable transmission fluid pressure gauges, other suitable gauges may be used

Description	Source	Part Number
Ashcroft 0-300PSI Vibration Dampened	Grainger	351009SW02LXLL300

Lang Instruments Model 5TUL8 (requires piston-type pressure gauge snubber)	<ul style="list-style-type: none"> • Rotunda RTTP • Grainger 	<ul style="list-style-type: none"> • Gauge: STATU16A • Snubber: 5TUL8
Snap-On 0-500PSI Gauge and Boot	Snap-On	EEPV5-500G
Waekon Digital Pressure Gauge	Rotunda RTTP	WAE48165
Pressure Pro PC 5000	Rotunda RTTP	300-WAE48365

2. Prepare the transmission LPC solenoid circuit CET50 to be back probed at the transmission electrical connector by removing the connector cover. Access to the LPC solenoid circuit CET50, WH-OG wire is required in a later step. Refer to Wiring, Cell 030 Transmission Controls and the video link at the start of the Service Procedure in this article.

NOTE: Back probing the LPC solenoid circuit will set a DTC and illuminate the powertrain malfunction (wrench) indicator.

3. Using the latest software level of the FDRS and VCMM, start a session.

4. Using FDRS select the following PIDs.

- RPM_DSD #
- PVT Pressure (set scale to +/- 3447 kPa)
- TFT
- SSA_AMP #
- SSB_AMP #
- SSC_AMP #
- SSD_AMP #
- SSE_AMP #
- SSF_AMP #

5. Does the vehicle exhibit harsh/delayed engagement and/or harsh/delayed shift symptoms only when TFT is at 49°C (121°F) or below?

- (1). Yes - perform Step 6 while TFT is at or below 49°C (121°F).
- (2). No - perform Step 6 with TFT at or above 50°C (122°F).

6. Enter Live Display mode. Verify the vehicle is in P, emergency brake applied and TFT is at the appropriate temperature range identified in Step 5.

- (1). For each step below, highlight the PID to enable it and select #. Then control the PID with up/down arrows.
- (2). Command SSA_AMP # / SSB_AMP # / SSC_AMP # / SSD_AMP # / SSE_AMP # / SSF_AMP # to 0mA.
- (3). Decrease RPM_DSD # between 500-600 rpm.
- (4). Ground the LPC circuit to elevate line pressure using a VCMM Universal Probe Tip Adapter (Rotunda 164-R9834, or equivalent) along with a suitable multimeter lead wire and probe (Figure 3) to back probe and ground the LPC solenoid circuit CET50. (Figure 4) Once line pressure has elevated and stabilized the ground probe is no longer needed to maintain elevated line pressure.

NOTE: Figure 4 shows back probing a PCM connector, other connectors are similar.

NOTE: Actual line pressure reading is expected to be less than commanded line pressure.

- (5). Record the pressure value observed on the gauge as Pre Ramp.
- (6). Command SSA_AMP # to 1.0A (five quick up arrow clicks).
- (7). Record the pressure value observed on the gauge as Applied A.

- (8). Command SSA_AMP # to 0mA (five quick down arrow clicks).
- (9). Command SSC_AMP # to 1.0A (five quick up arrow clicks).
- (10). Record the pressure value observed on the gauge as Applied C.
- (11). Command SSC_AMP # PID off to 0mA (five quick down arrow clicks).
- (12). Test is complete. Release control of all parameters then turn the ignition off.
- (13). Remove back probe from the LPC circuit connector and reinstall the connector cover.
- (14). Turn the ignition on (KOEO) and clear all CMDTCs.
- (15). Turn the ignition off.

7. Download the CDF calculator tool.

NOTE: The calculator is an ".exe" file type. Make sure the computer firewall is set to allow this type of file to download.

- (1). [Click here to download the CDF calculator tool in English.](#)
- (2). [Click here to download the CDF calculator tool in Spanish.](#)
- (3). [Click here to download the CDF calculator tool in French.](#)

8. Enter the value recorded as Pre Ramp into CDF calculator for both fields Pre Ramp Valley and Pre Ramp Peak.

9. Enter the value recorded as Applied A into CDF calculator for both fields Applied A Valley and Applied A Peak.

10. Enter the value recorded as Applied C into CDF calculator for both fields Applied C Valley and Applied C Peak.

11. Refer to CDF calculator results. Does the "A-clutch Leakage Rate %" field display green?

- (1). Yes - proceed to Step 12.
- (2). No (field displays red) - this article does not apply. Refer to WSM, Section 307-01 > Diagnosis and Testing > A Clutch.

12. Does the "C-Clutch vs A-Clutch %" field display green?

- (1). Yes - this article does not apply. Refer to WSM, Section 307-01 for normal diagnostics.
- (2). No (field displays red) - proceed to "Repair Procedure" in this article.

Repair Procedure

1. Remove the transmission and mount the transmission to the bench. Refer to WSM, Section 307-01.

2. Disassemble the transmission. Perform only the necessary steps to remove the clutch and planetary assembly from the transmission case. Refer to WSM, Section 307-01.

- (1). It is only necessary to remove the torque converter, transmission fluid pan and gasket, transmission fluid auxiliary pump (if equipped), fluid filter and main control valve body assembly, all 4 speed sensors (intermediate speed sensor A [ISSA], intermediate speed sensor B [ISSB], TSS and OSS), transmission fluid pump, front support assembly and the clutch and planetary assembly. Refer to WSM, Section 307-01.

3. Disassemble the clutch and planetary assembly. Perform only the necessary steps to remove the clutch and planetary container cylinder, the CDF clutch cylinder and the No. 3 sun gear shaft and No. 2 ring gear assembly from the clutch and planetary assembly. Refer to WSM, Section 307-01.

- (1). It is only necessary to remove the A clutch assembly, the selective shim and T3 thrust bearing, remove and discard the 5-input shaft front seals.
- (2). Remove the No. 1 planetary carrier snap ring, clutch and planetary container cylinder, the No. 4 ring gear snap ring and the No. 4 ring gear from the clutch and planetary container cylinder. Discard the clutch and planetary container cylinder. Refer to WSM, Section 307-01.

- (3). Remove the E clutch and input shaft assembly, the No. 3 planetary carrier and No. 3 sun gear, the No. 3 sun gear shaft and No. 2 ring gear assembly. Refer to [WSM](#), Section 307-01.
4. Remove and discard the sun gear No. 3 shaft seals. Install the 4 new sun gear No. 3 shaft seals. Refer to [WSM](#), Section 307-01.
5. Disassemble the C, D and F clutch assemblies from the CDF cylinder. Discard the CDF cylinder. Refer to [WSM](#), Section 307-01.
6. Assemble the C, D and F clutch assemblies into the new CDF clutch cylinder. Refer to [WSM](#), Section 307-01.
7. Perform the C, D and F clutch pack end play measurements for proper clearance. Refer to [WSM](#), Section 307-01.
8. Remove and discard the input shaft-to-sun gear No. 3 shaft seals. Install the 5 new input shaft-to-sun gear No. 3 shaft seals. Refer to [WSM](#), Section 307-01.
9. Remove and discard the input shaft seal. Install the new input shaft seal. Refer to [WSM](#), Section 307-01.
10. Install the 5 new input shaft front seals. Refer to [WSM](#), Section 307-01.
11. Install the No. 4 ring gear and snap ring into a new clutch and planetary container cylinder.
12. To reassemble the clutch and planetary assembly, reverse the disassembly procedure. Refer to [WSM](#), Section 307-01.
13. Perform the T3 thrust bearing measurement to set transmission front end clearance. Refer to [WSM](#), Section 307-01.
14. Reassemble the transmission. Refer to [WSM](#), Section 307-01.
15. Install the transmission. Refer to [WSM](#), Section 307-01.
16. Perform an adaptive learning drive cycle. Refer to [WSM](#), Section 307-01.

NOTE: Advise the customer that this vehicle is equipped with an adaptive transmission shift strategy which allows the vehicle's computer to learn the transmission's unique parameters and improve shift quality. When the adaptive strategy is reset, the computer will begin a relearning process. This relearning process may result in firmer than normal upshifts and downshifts for several days.

© 2025 Ford Motor Company

All rights reserved.

NOTE: The information in Technical Service Bulletins is intended for use by trained, professional technicians with the knowledge, tools, and equipment to do the job properly and safely. It informs these technicians of conditions that may occur on some vehicles, or provides information that could assist in proper vehicle service. The procedures should not be performed by "do-it-yourselfers". Do not assume that a condition described affects your car or truck. Contact a Ford or Lincoln dealership to determine whether the Bulletin applies to your vehicle. Warranty Policy and Extended Service Plan documentation determine Warranty and/or Extended Service Plan coverage unless stated otherwise in the TSB article. The information in this Technical Service Bulletin (TSB) was current at the time of printing. Ford Motor Company reserves the right to supersede this information with updates. The most recent information is available through Ford Motor Company's on-line technical resources.