

Charging System - System Operation and Component Description

System Operation

System Diagram

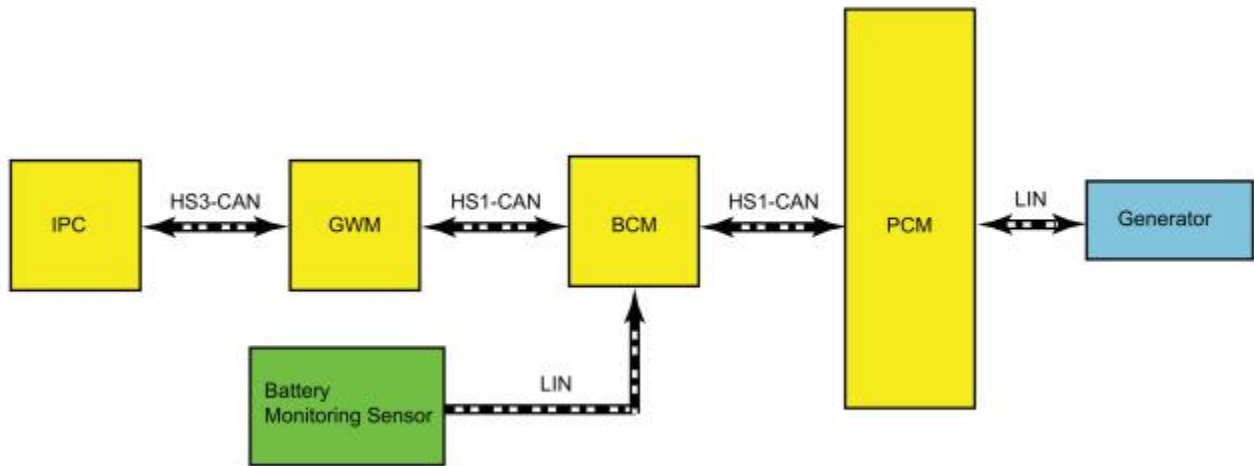

E254038

Network Message Chart

Module Network Input Messages — Body Control Module (BCM)

Broadcast Message	Originating Module	Message Purpose
Alternator fault	<u>PCM</u>	The <u>PCM</u> has detected a fault in the generator or generator circuits.

Module Network Input Messages — Instrument Panel Cluster (IPC)

Broadcast Message	Originating Module	Message Purpose
Power system status	<u>BCM</u>	Reports any generator/charging system faults. Used for charging system fault indicator.

Module Network Input Messages — Powertrain Control Module (PCM)

Broadcast Message	Originating Module	Message Purpose
Load Shed Request	<u>BCM</u>	Used to indicate what level of load shed is commanded.
Vehicle speed	<u>ABS module</u>	Vehicle speed is reported via. Used by the <u>PCM</u> during charging system voltage calculation.

Charging System

The PCM controlled Smart Charge charging system determines the optimal voltage setpoint for the charging system and communicates this information to the voltage regulator. The Smart Charge charging system is designed to set a DTC when a charging system fault is present. All of the Diagnostic Trouble Codes (DTCs) can set continuous faults, but not all Diagnostic Trouble Codes (DTCs) set as on-demand faults.

The smart regenerative charge system primary strategy is stored in the BCM. The BCM receives information relating to the battery condition from the battery monitoring sensor via a LIN. The BCM calculates and sends the set value needed for the generator charging voltage via the HS-CAN to the PCM. The PCM then adjusts the value received (if necessary) and sends it to the generator via a different LIN. The charging voltage is adjusted depending on various parameters, such as the current level of engine efficiency. The smallest possible set value for the generator voltage is 12.2 volts, while the maximum charging voltage can be anywhere between 14.5 and 14.9 volts. However, when the battery is in a refresh phase, the voltage may occasionally reach up to 15.2 volts. These refresh phases are required when the battery charge status is 80% over long periods of time, which increases the risk of sulfation in the battery cells.

The PCM simultaneously controls and monitors generator output. When the current consumption is high or the battery is discharged, the PCM raises engine speed as needed to increase generator output. The generator charges the battery and at the same time supplies power for all electrical loads. The battery is more effectively charged with a higher voltage when the battery is cold and a lower voltage when the battery is warm.

The PCM turns off the generator during cranking to reduce the generator load and improve cranking speed. Once the engine starts, the PCM slowly increases generator output to the desired voltage.

The PCM reports any charging system faults and sends a message through the HS-CAN to the BCM. The BCM then sends a message over the MS-CAN to the IPC, which controls the charging system warning indicator. The status of the PCM charging system warning indicator message can be confirmed by viewing the PCM Generator Fault Indicator Lamp (GENFIL) PID. Any charging system fault detected by the PCM results in 1 or more Diagnostic Trouble Codes (DTCs) being set and the GENFIL PID having a status of ON. If equipped with a charging system warning indicator, the IPC turns the indicator on or off. If equipped with a message center, the IPC displays the corresponding message to notify the driver of the condition.

Under certain circumstances, the charging system may have a concern but still keeps the battery charged while the vehicle is running. The LIN is normally used to initiate charging, but with a fault in this circuit the generator self-excites or begins charging on its own. The charging system warning indicator is illuminated and/or the corresponding message to notify the driver of the condition is displayed and the generator operates in a default mode (approximately 13.5 volts).

Electrical Energy Management System

NOTICE: When any vehicle module is being programmed, connect an external battery charger to make sure the module programming is completed without interruption due to the load shedding feature becoming active. The external battery charger must maintain a system voltage above 13 volts. This may require a charger setting higher than the lowest charge setting. The external battery charger negative connection must be made to an engine or vehicle chassis ground and not the negative battery terminal. If the connection is to the negative battery terminal, load shedding may begin and module programming may be corrupted. After charging has begun, start the engine to clear any load shed states and then turn the engine off and proceed with programming.

This vehicle is equipped with an Electrical Energy Management system which manages battery charging and monitors the battery state of charge. The Electrical Energy Management system also utilizes a load shed strategy to help control discharge of the battery and prevent, when possible, an excessively low battery state of charge. The BCM uses a battery monitoring sensor to monitor the battery state of charge.

To maintain correct operation of the load shed system, any electrical devices or equipment must be grounded to the chassis ground and not the negative battery terminal. A connection to the negative battery terminal causes an inaccurate measurement of the battery state of charge and incorrect load shed system operation due to the current being used bypassing the battery monitoring sensor. Refer to the Battery Monitoring Sensor component description in this section.

Battery State of Charge

The Electrical Energy Management system monitors the battery current flow and voltage to determine the battery state of charge. During the drive cycle the Electrical Energy Management system software monitors the charge and discharge current and increases the state of charge during charging, and decreasing it during discharge. During rest periods (key off with no electrical loads) when the vehicle enters sleep mode, the battery voltage is sampled to calibrate the state of charge. The sensor automatically executes this calibration anytime the vehicle enters sleep mode and when the total vehicle current draw is below 300mA. It takes 4 to 6 hours in the sleep mode to calibrate the battery state of charge to high accuracy. If the system draw does not allow the battery state of charge calibration over the previous 7 to 10, days the state of charge quality factor changes to flag this and some Electrical Energy Management system functions, which rely on the accuracy of the battery state of charge, may be temporarily turned off until a calibration takes place.

NOTE: *Any devices left attached to the power socket that draw in excess of 200mA (or less depending on other battery loads), prevents a battery monitoring sensor from calibrating the battery state of charge.*

Engine Off Load Shed

When the ignition is in ACC or ON mode and the BCM determines the battery voltage or the battery state of charge has dropped below set levels, a low battery warning message is displayed in the message center. Should the battery voltage or the battery state of charge continue to drop, the audio system is powered down to save the remaining battery charge. This load shed state clears once the vehicle is started and battery state of charge is allowed to recover.

When the ignition is in the ON mode and load shed occurs, the message center displays the corresponding message to notify the driver that battery protection actions are active. The audio system shuts down after the message center displays the warning.

If a fault occurs with the battery monitoring sensor or circuit(s), the only engine off load shed strategy that is active is a 45 minute timer. After 45 minutes have elapsed, the audio system turns off. To clear the load shed state, restart the engine.

Battery Charging

When it is required to charge the vehicle battery, connect the positive connection to the battery positive post, and place the charger negative cable to vehicle ground. Do not connect the negative charger cable to the battery negative terminal. Connecting directly to the battery negative terminal bypasses the vehicle sensors, not allowing the battery monitoring sensor to detect the charge current. As a result the battery state of charge does not reflect the charging. Look for the body ground cable coming off the clamp or the battery monitoring sensor and try and connect in this location (typically on the shock tower sheet metal). The placement of the battery is such that the battery negative terminal is located under the sheet metal shroud making sheet metal ground the obvious choice for the charger.

If the battery is being charged due to a load shedding message, only properly charging the battery assists in clearing this message. If the charger was improperly installed, the Electrical Energy Management system calibrates the battery state of charge after about 8 hours.

NOTICE: If the charger is incorrectly connected to the battery negative terminal, DO NOT reset the battery monitoring system using the diagnostic scan tool. This reset is reserved for new battery installation only. This reset will clear the learned battery data, the battery time in service, and will affect the aging algorithm parameters, which have been learned since the installation of the battery.

Jump Starting

When it is required to jump start the vehicle, just like battery charging, it is important to connect the cables properly for the Electrical Energy Management system to measure the energy input to the system to keep an accurate state of charge. Connect the positive connection to the battery positive post, and connect the negative cable to a vehicle ground. Do not connect to the negative battery terminal. Connecting directly to the battery negative terminal bypasses the ability of the vehicle to measure the input current with the battery monitoring sensor, and does not adjust the battery state of charge accordingly. For a convenient ground location look for the body ground cable coming off the clamp or the battery monitoring sensor and try and connect in this location (typically on the shock tower sheet metal). The Electrical Energy Management system calibrates the battery state of charge as described above after about 8 hours if the jump start negative cable is improperly installed.

NOTICE: If the cables are incorrectly connected to the battery negative terminal, DO NOT reset the battery monitoring system using the diagnostic scan tool. This reset is reserved for new battery installation only. This reset will clear the learned battery data, the battery time in service, and will affect the aging algorithm parameters, which have been learned since the installation of the battery.

Battery Replacement

If the vehicle battery is replaced, it is very important to perform the battery monitoring system reset using the diagnostic scan tool. If the battery monitoring system reset is not carried out, it holds the old battery parameters and time in service counter in memory. Additionally it tells the system the battery is in an aged state and may limit the Electrical Energy Management system functions.

Component Description

Generator

The generator is equipped with an electronic internal voltage regulator.

Battery Monitoring Sensor

NOTICE: Unless the battery is being replaced, DO NOT reset the battery monitoring system using the diagnostic scan tool. This reset is reserved for new battery installation only. This reset will clear the learned battery data, the battery time in service, and will affect the aging algorithm parameters, which have been learned since the installation of the battery.

The battery monitoring sensor is integrated with the negative battery terminal clamp and cable assembly, which provides a ground to the sensor. The battery monitoring sensor measures voltage, current, and temperature of the battery and uses these inputs to calculate the battery condition. The sensor transmits this information through the LIN circuit to the BCM. The battery monitoring sensor has a 2-pin connector providing battery voltage and LIN connections.

The battery monitoring sensor is an input to the Electrical Energy Management system software. If the sensor malfunctions due to wiring issues or failure, a DTC sets. In most cases the Electrical Energy Management system functions are turned off until the sensor operation is restored.

Powertrain Control Module (PCM)

The PCM monitors and controls the charging system.