

EN INSTALLATION INSTRUCTION
TRAILER HITCH

E INSTRUCCIONES DE INSTALACIÓN
ENGANCHE DEL REMOLQUE

F INSTRUCTIONS D'INSTALLATION
ATTELAGE DE REMORQUE



© Copyright Ford 2018
Printed Copies are uncontrolled

Expert Fitment Required
Se necesita realizar el montaje con expertos
Montage requis par un expert

Subject to alteration without notice
Sujeto a cambios sin previo aviso
Susceptible de modification sans préavis

RANGER

2019

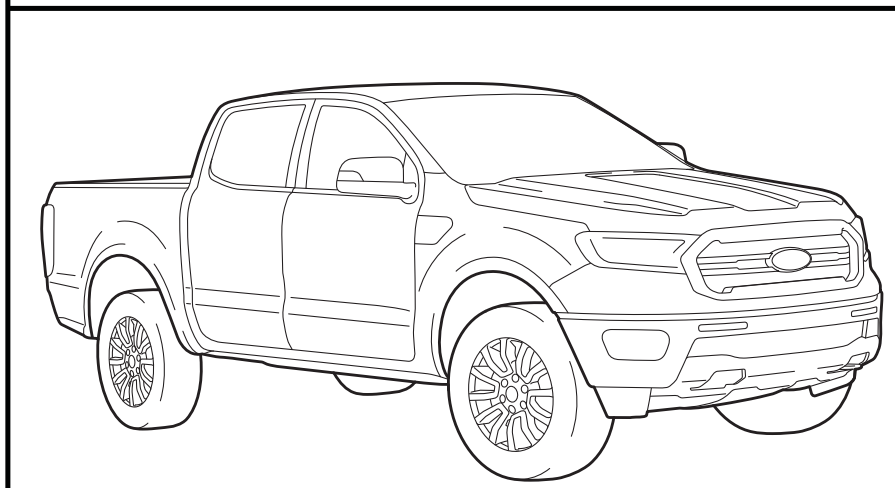

EN **STOP! PRIOR TO BEGINNING YOU MUST HAVE PROPER ADHESIVE— MOTORCRAFT PART NUMBER: TA-9**
www.fcsdchemicalsandlubricants.com
IF MOTORCRAFT TA-9 IS UNAVAILABLE IN YOUR AREA, USE LORD FUSOR 153. TO OBTAIN LOCALLY
CONTACT LORD CORPORATION 1-877-ASK-LORD (1-877-275-5673)

E **¡PARE! ANTES DE COMENZAR, DEBE TENER EL NÚMERO DE PARTE DEL ADHESIVO MOTORCRAFT**
APROPIADO: TA-9 www.fcsdchemicalsandlubricants.com
SI MOTORCRAFT TA-9 NO ESTÁ DISPONIBLE EN SU ÁREA, UTILICE LORD FUSOR 153. PARA OBTENERLO
LOCALMENTE, CONTACTE A LORD CORPORATION AL 1-877-ASK-LORD (1-877-275-5673)

F **STOP ! AVANT DE COMMENCER, VOUS DEVEZ VEILLER À DISPOSER DE L'ADHÉSIF ADAPTÉ — RÉFÉRENCE**
MOTORCRAFT : TA-9 www.fcsdchemicalsandlubricants.com
SI LE MOTORCRAFT TA-9 N'EST PAS DISPONIBLE DANS VOTRE RÉGION, UTILISEZ LORD FUSOR 153. POUR
VOUS LE PROCURER LOCALEMENT CONTACTEZ LORD CORPORATION 1-877-ASK-LORD (1-877-275-5673)

A

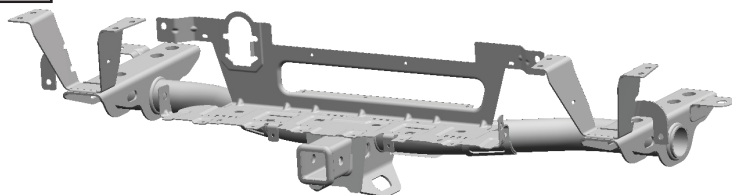

D

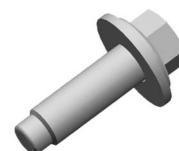

X 2

B



C



E



X 4



TOOLS REQUIRED
HERRAMIENTAS NECESARIAS
OUTILS NÉCESSAIRES

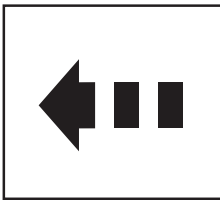
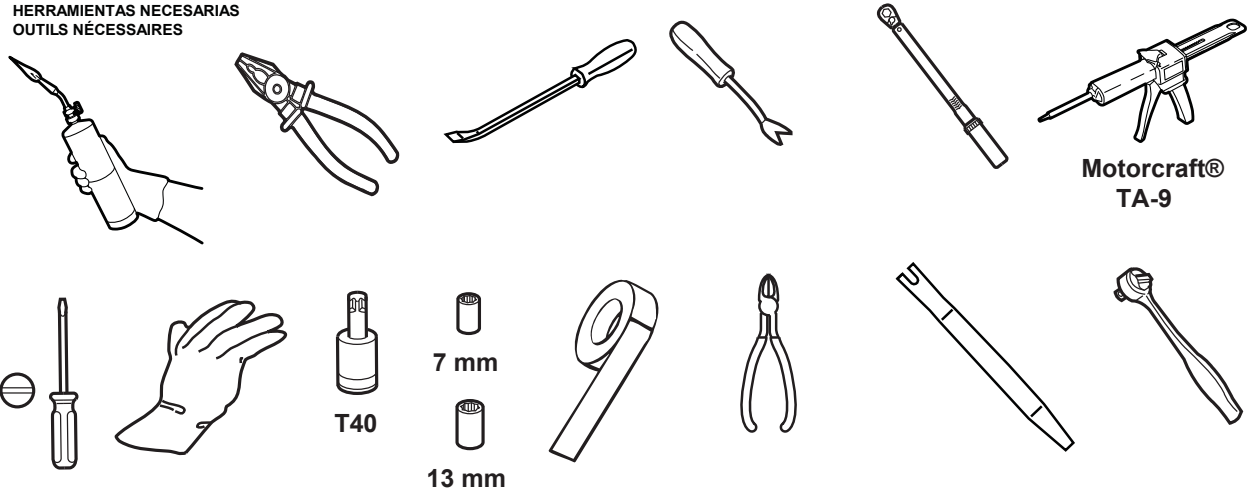

- (EN) Motion Arrow
- (E) Flecha de movimiento
- (F) Flèche de déplacement

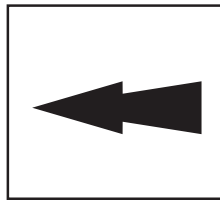

- (EN) Item Arrow
- (E) Flecha del artículo
- (F) Flèche d'élément

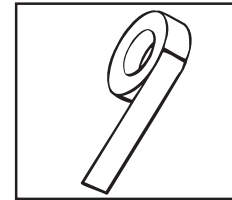

- (EN) Tape Up
- (E) Utilice cinta
- (F) Enrubanner



- (EN) See Workshop Manual
- (E) Consulte el manual del taller
- (F) Voir le manuel d'atelier

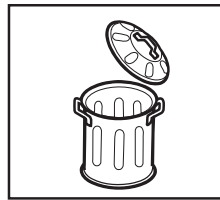

- (EN) Throw away
- (E) Desechar
- (F) Jeter

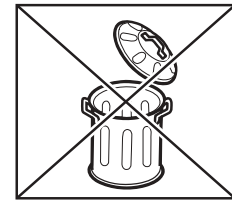

- (EN) Do Not Throw Away
- (E) No lo deseche
- (F) Ne pas jeter

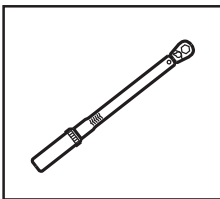

- (EN) Use Torque Wrench
- (E) Utilice una llave para ajustar
- (F) Utiliser une clé dynamométrique

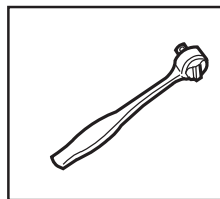

- (EN) Use Ratchet
- (E) Utilice la rueda dentada
- (F) Utiliser un rochet

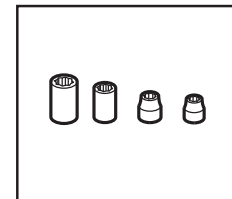

- (EN) Use Specified Sockets
- (E) Utilice los tomacorrientes especificados
- (F) Utiliser les douilles spécifiées

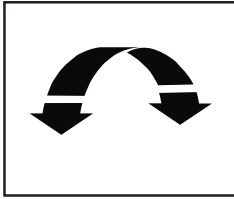

- (EN) Both Sides
- (E) Ambos lados
- (F) Des deux côtés

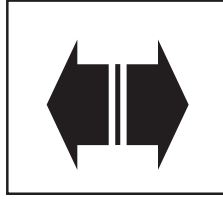

- (EN) Disconnect Arrow
- (E) Desconecte la flecha
- (F) Flèche de déconnexion

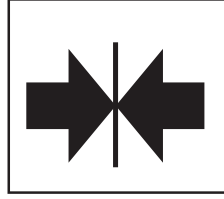

- (EN) Connect Arrow
- (E) Conecte la flecha
- (F) Flèche de connexion

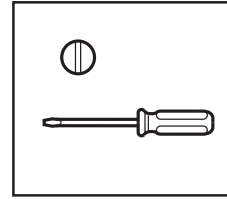

- (EN) Use Flat End Screwdriver
- (E) Utilice un destornillador de punta plana
- (F) Utiliser un tournevis à tête plate

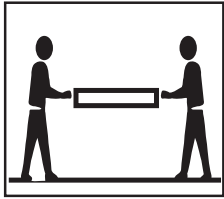

- (EN) Two People Carry
- (E) Para dos personas
- (F) Par deux personnes

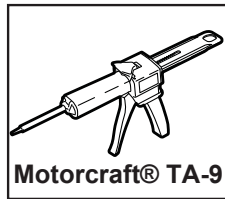

- (EN) Apply Specified Adhesive
- (E) Aplique el adhesivo especificado
- (F) Appliquer l'adhésif spécifié

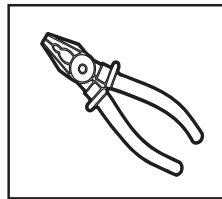

- (EN) Use Pliers
- (E) Use pinzas
- (F) Utiliser des pinces

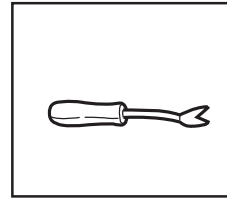

- (EN) Use Trim Tool
- (E) Utilice la herramienta para desbaste
- (F) Utiliser un outil de garnissage

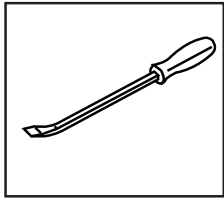

- (EN) Use Pry bar
- (E) Utilice la palanca
- (F) Utiliser un pied-de-biche



- (EN) Caution Symbol
- (E) Símbolo de precaución
- (F) Symbole d'avertissement

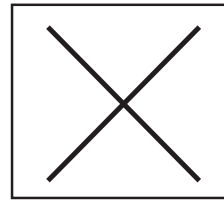

- (EN) Incorrect Symbol
- (E) Símbolo incorrecto
- (F) Symbole signifiant Incorrect

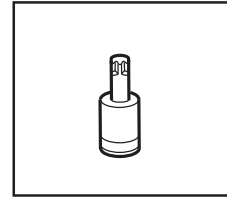

- (EN) Use Torx Bit (Ratchet)
- (E) Utilice punta Torx (rueda dentada)
- (F) Utiliser un embout Torx (sur clé à cliquet)



- (EN) Correct Symbol
- (E) Símbolo correcto
- (F) Symbole signifiant Correct

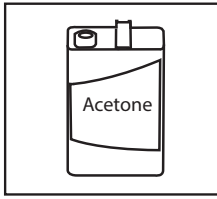

- (EN) Use Acetone
- (E) Utilice acetona
- (F) Utiliser de l'acétone

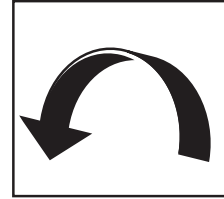

- (EN) Turn Component
- (E) Gire el componente
- (F) Composant pivotant

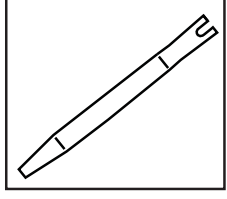

- (EN) Use Plastic Trim Tool
- (E) Utilice la herramienta para desbaste de plástico
- (F) Utiliser un outil de garnissage en plastique

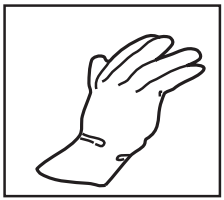

- (EN) Wear Protective Gloves
- (E) Use guantes de protección
- (F) Porter des gants de protection

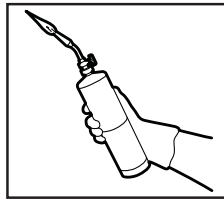

- (EN) Use Propane Torch
- (E) Utilice la antorcha de propano
- (F) Utiliser un chalumeau au propane

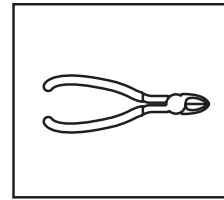

- (EN) Use Side Cutters
- (E) Utilice pinzas de corte lateral
- (F) Utiliser une pince coupante de côté

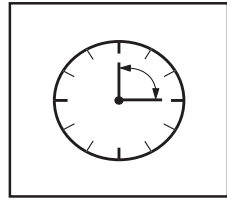

- (EN) Specified Time Requirement
- (E) Requisito de tiempo especificado
- (F) Exigence de délai requis



- (EN) Save bolts for installation.
- (E) Guarde los pernos para la instalación..
- (F) Conserver les boulons pour la pose.

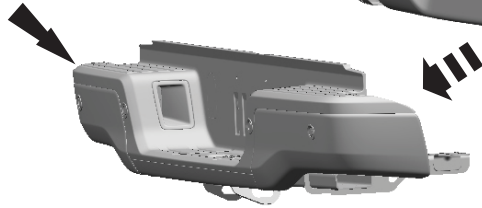
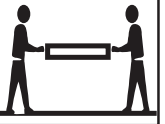

1

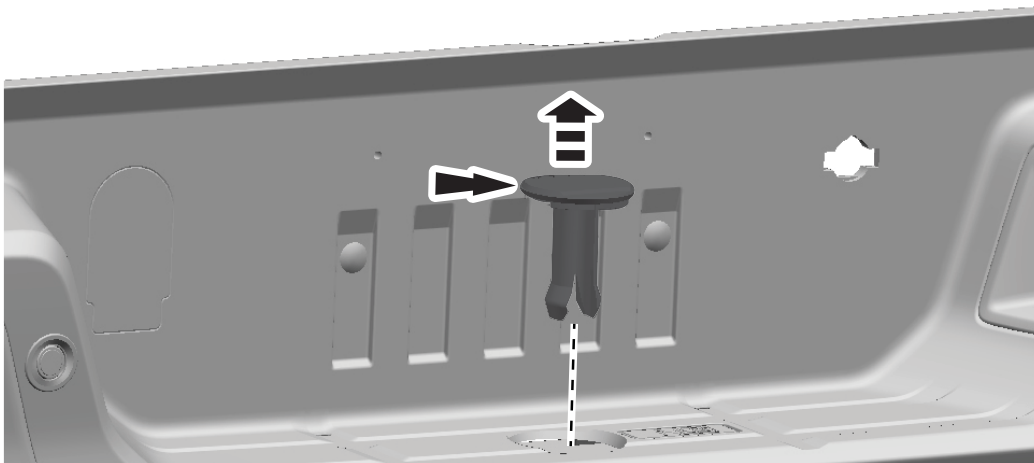

2

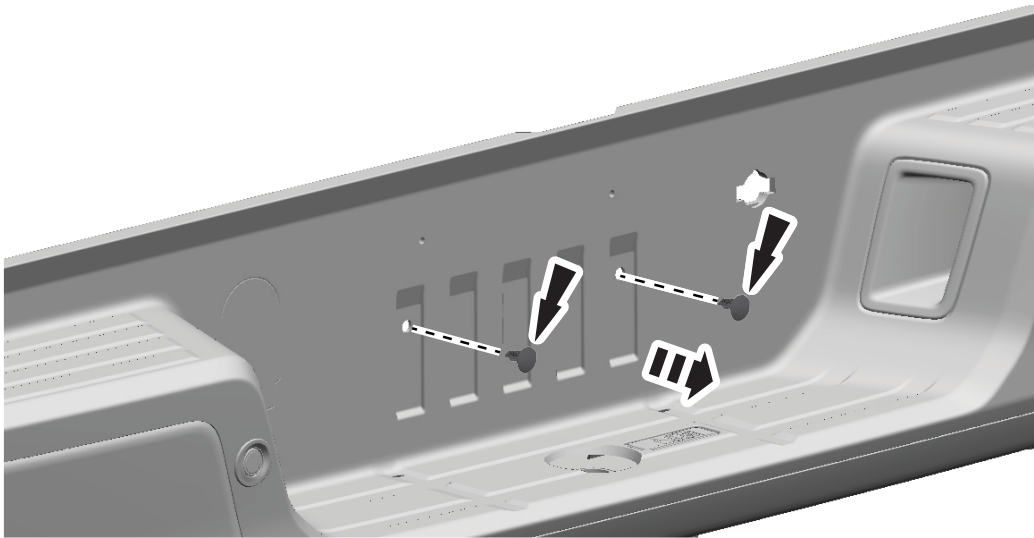

3

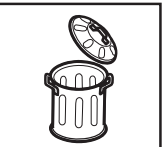
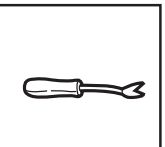

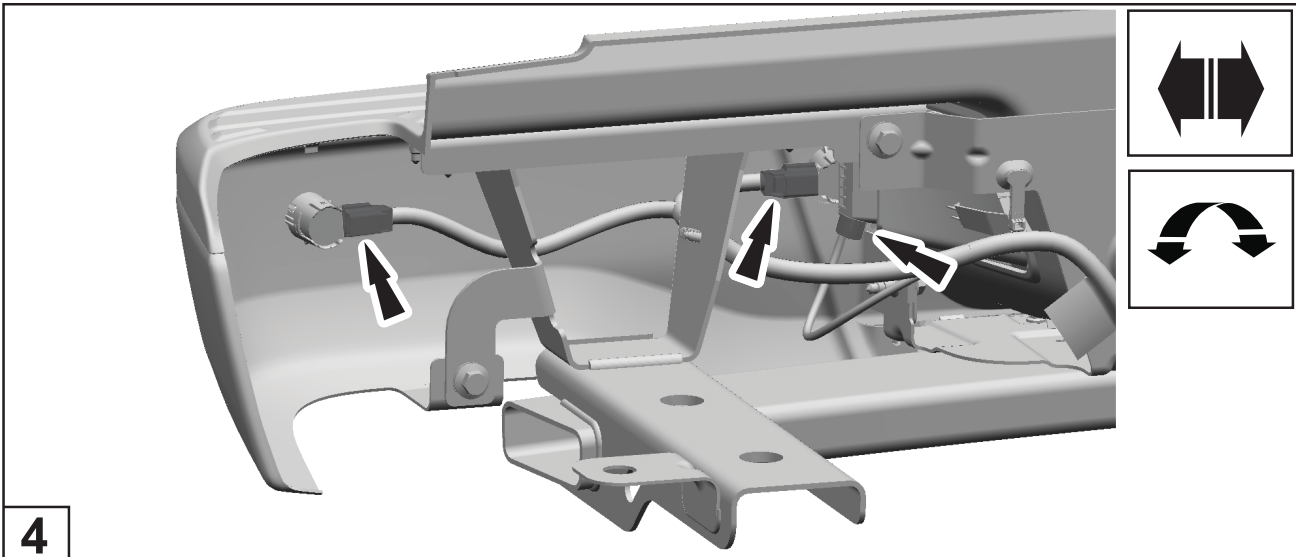

4

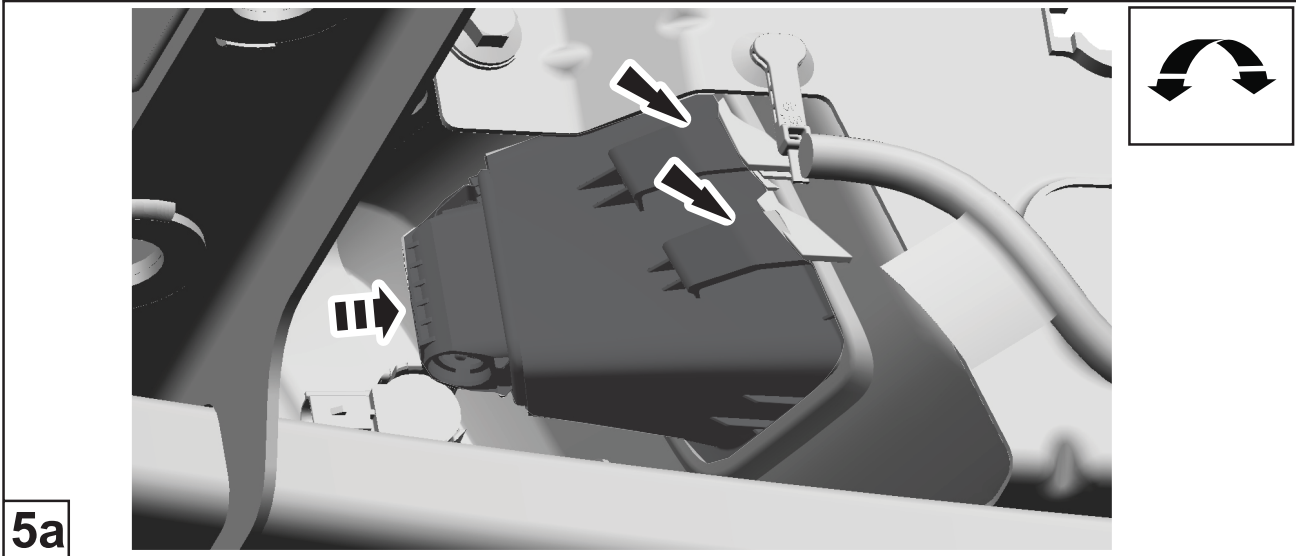

5a

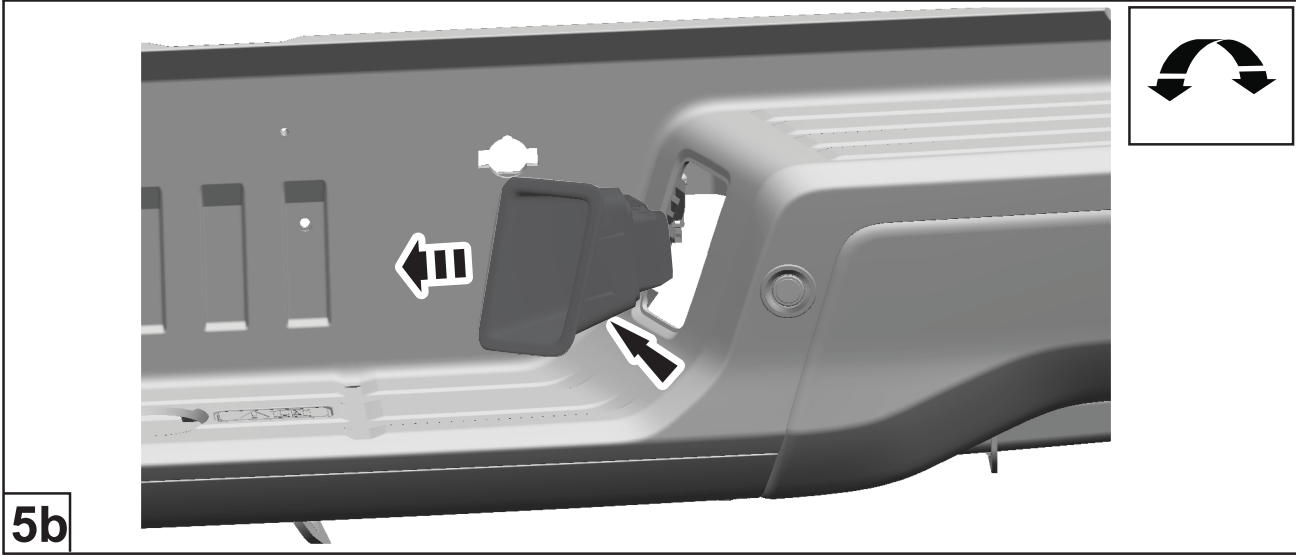

5b



6a

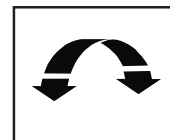
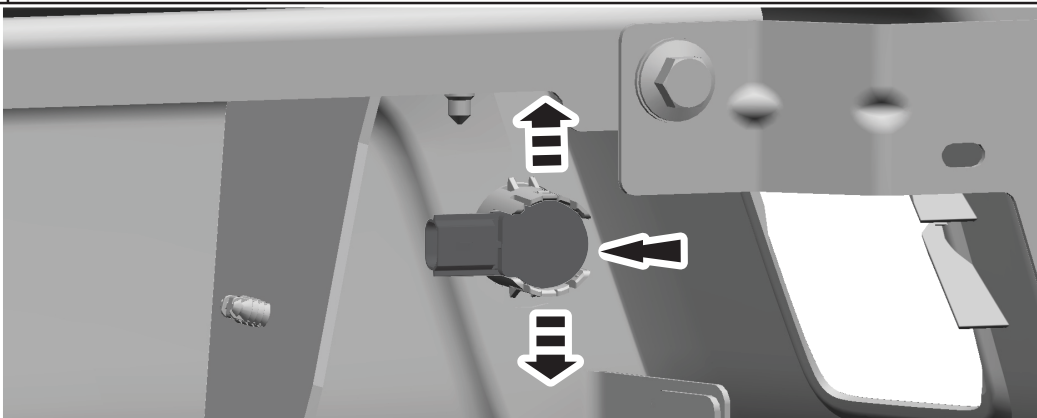

(EN) Release the tabs to remove the sensor. Use care as tabs are fragile.

(E) Suelte las lengüetas para quitar el sensor. Hágalo con cuidado ya que las lengüetas son frágiles.

(F) Défaire les languettes pour déposer le capteur. Faire preuve de prudence car les languettes sont fragiles.

6b

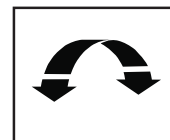
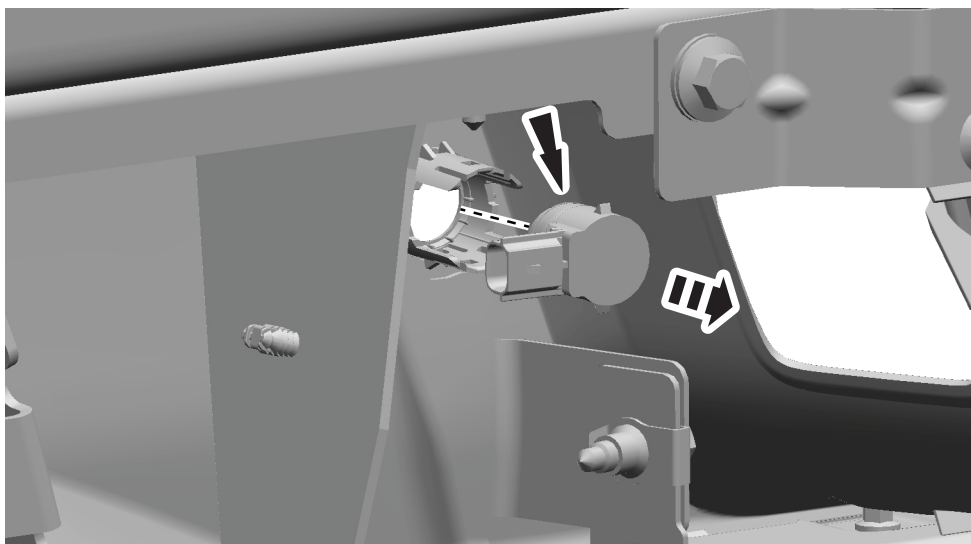

6c



7

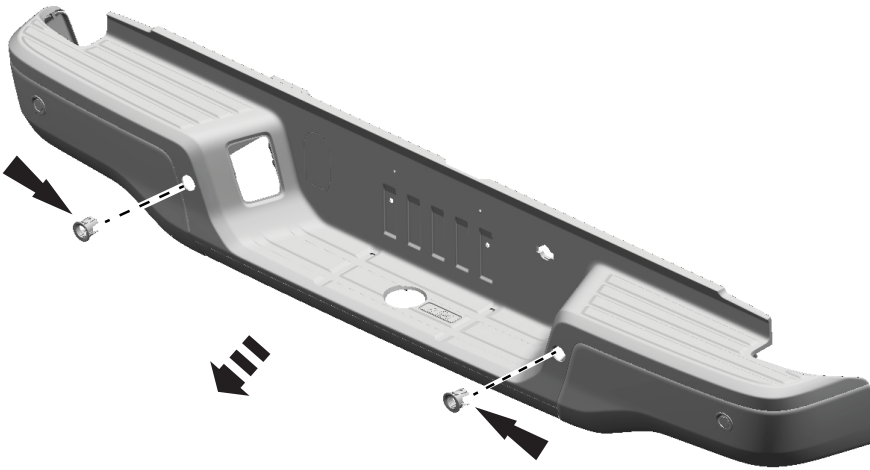

8a

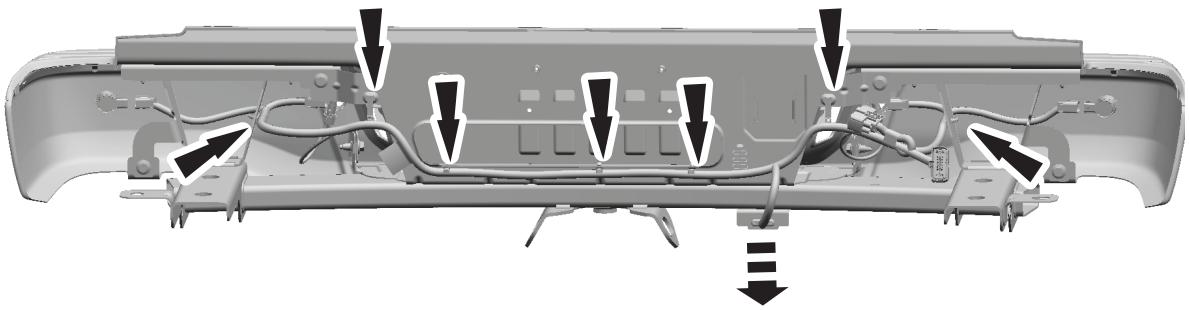

8b

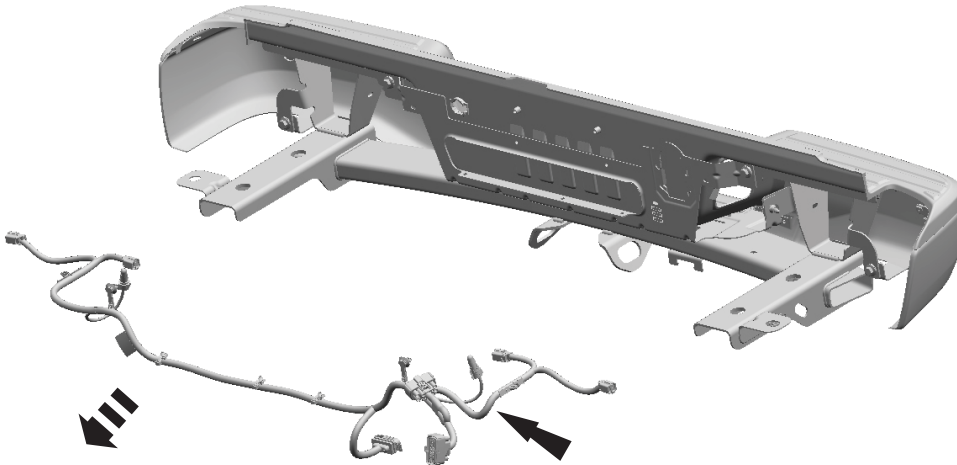

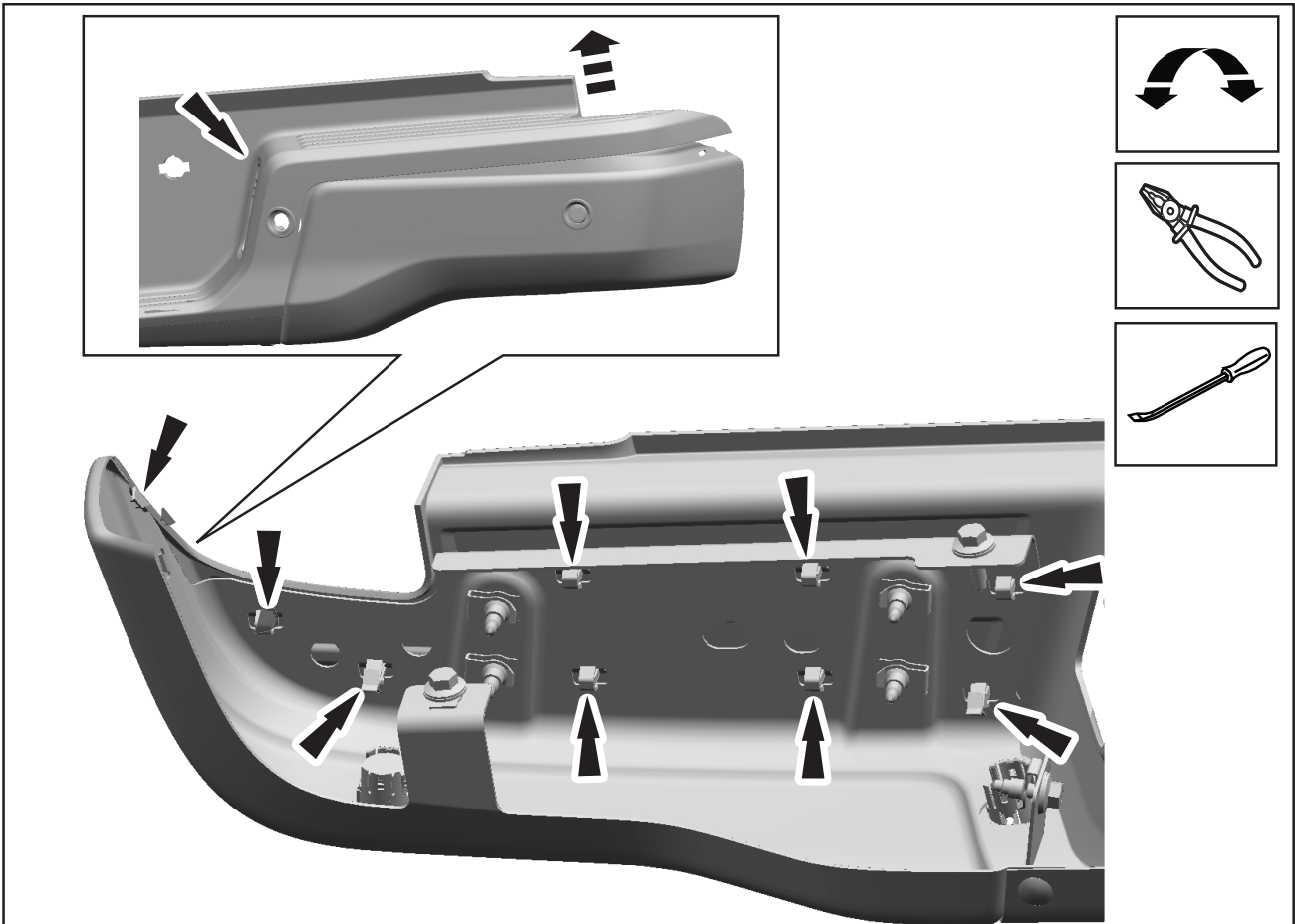

- 9a**
- (EN) Use pliers to release the retainers. Work upward as each retainer is released. Use caution not to damage while removing the step pad. Appearance issues may occur.
 - (E) Use las pinzas para liberar los retenes. Trabaje hacia arriba a medida que se libera cada retén. Use precaución para no generar daño mientras remueve el protector del estribo. Es posible que haya problemas con la apariencia.
 - (F) Utiliser des pinces pour défaire les retenues. Procéder vers le haut une fois chaque retenue détachée. Faire attention à ne pas provoquer de dommages en retirant le marchepied. Des défauts esthétiques peuvent apparaître.

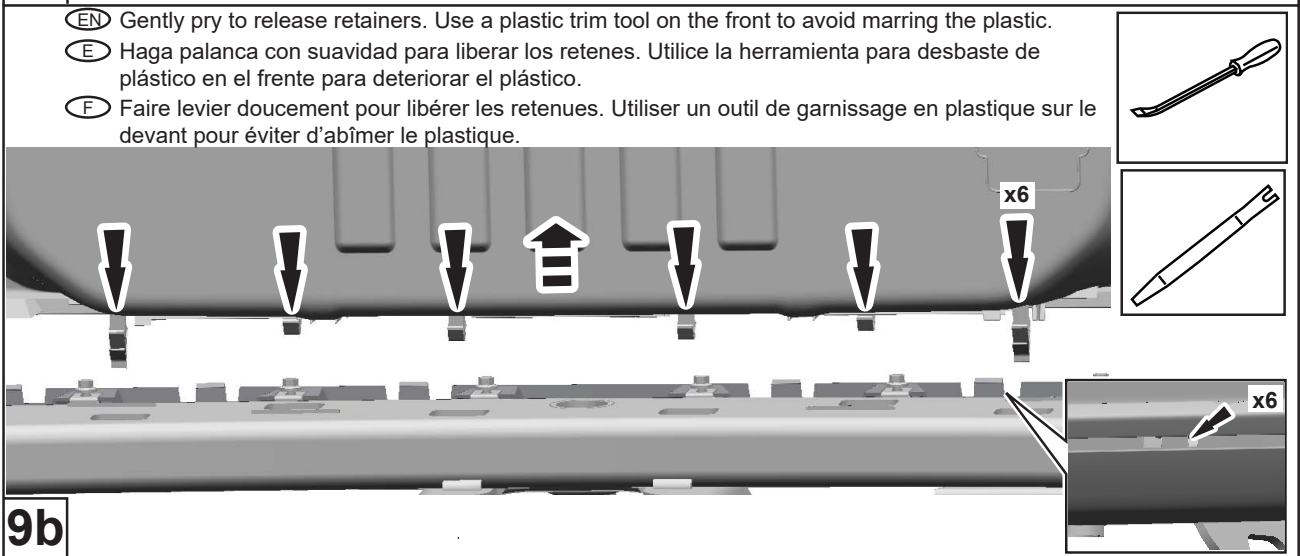

- (EN) Gently pry to release retainers. Use a plastic trim tool on the front to avoid marring the plastic.
- (E) Haga palanca con suavidad para liberar los retenes. Utilice la herramienta para desbaste de plástico en el frente para deteriorar el plástico.
- (F) Faire levier doucement pour libérer les retenues. Utiliser un outil de garnissage en plastique sur le devant pour éviter d'abîmer le plastique.

9b

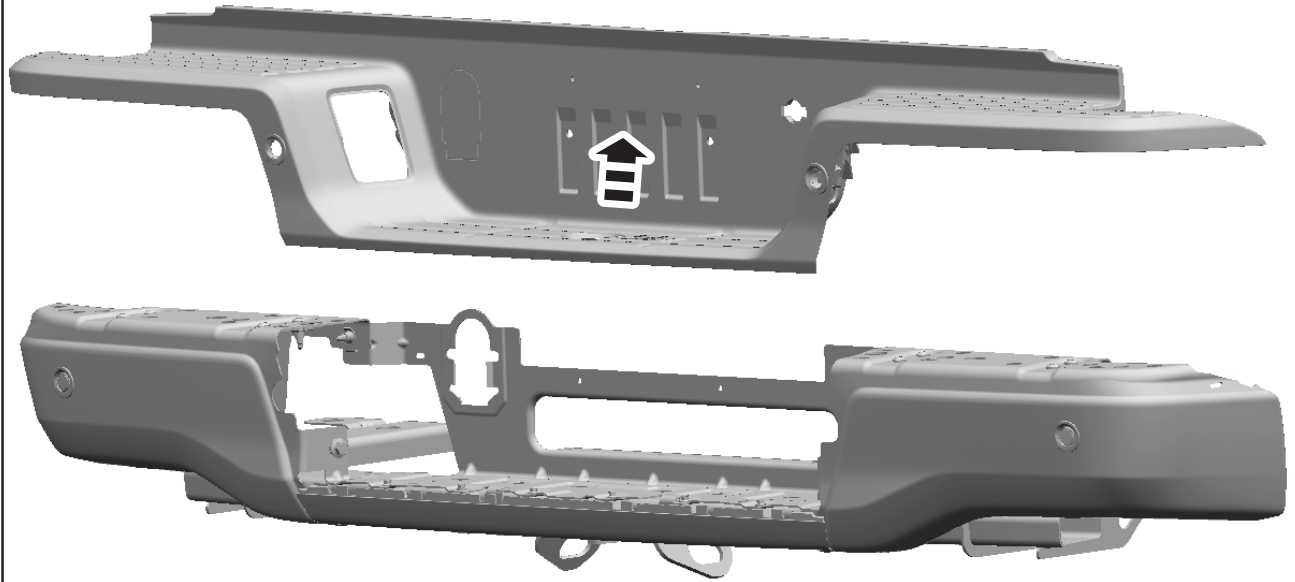

10

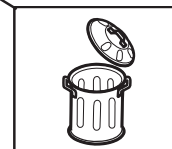
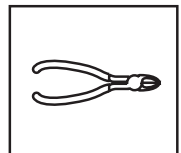
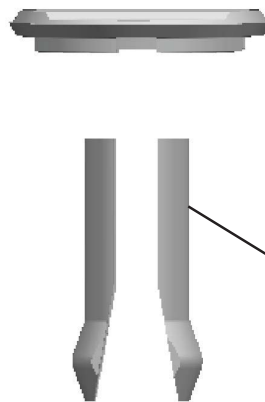

11

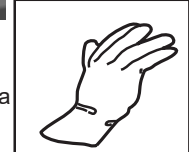
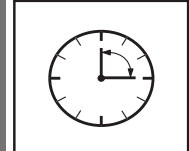
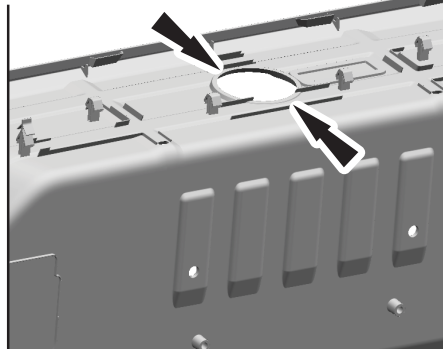
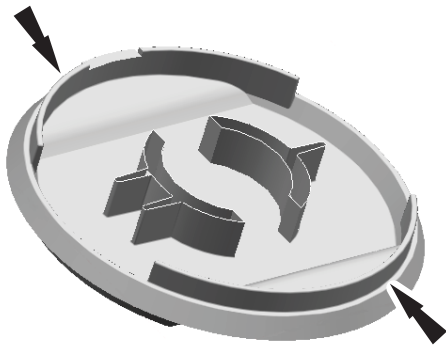

- (EN) Using Acetone, clean the edge of the cap and the underside of the bumper cover step pad where the cap will mate with the cover. Allow to dry for 2 minutes.
- (E) Al usar acetona, limpie el borde de la tapa y la parte inferior del protector del estribo de la cubierta del parachoques en donde la tapa se acoplará con la cubierta. Permita que se seque por 2 minutos.

12

- (F) Avec de l'acétone, nettoyer le bord du capuchon et le dessous du marchepied de couvercle du pare-chocs où le capuchon s'ajuste avec le couvercle. Laisser sécher 2 minutes.

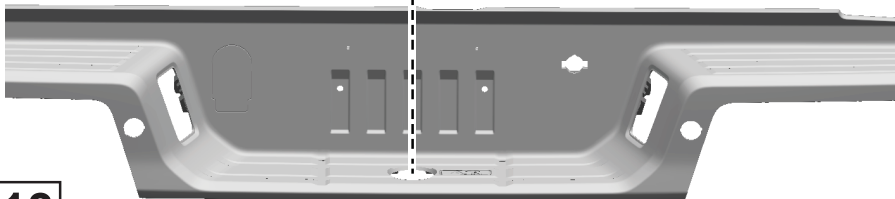
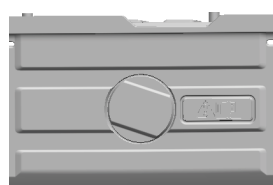

- (EN) Install the cap into the bumper cover step pad, make sure to align the cap with the bumper cover step pad features.
- (E) Instale la tapa en el protector del estribo de la cubierta del parachoques, asegúrese de alinear la tapa con las características del protector del estribo de la cubierta del parachoques.
- (F) Installer le capuchon dans le marchepied de couvercle du pare-chocs, veiller à aligner le capuchon avec les éléments du marchepied de couvercle du pare-chocs.

13

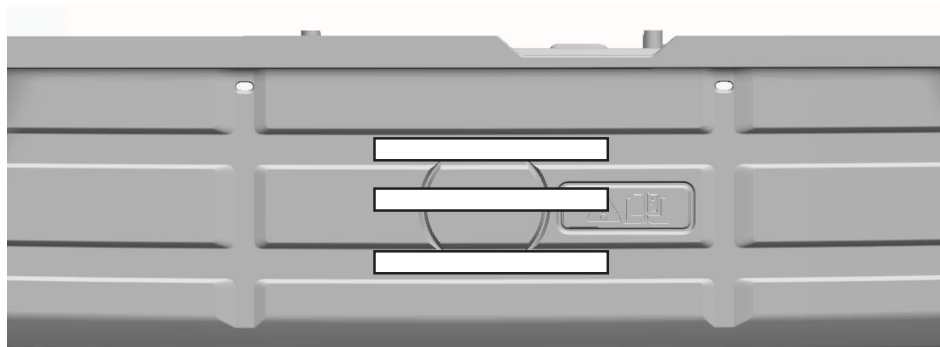

- (EN) Tape the cap to the bumper cover step pad, to keep alignment.
- (E) Encinta la tapa al protector del estribo de la cubierta del parachoques para mantener la alineación
- (F) Coller le capuchon sur le marchepied de couvercle du pare-chocs avec du ruban adhésif pour conserver l'alignement.

14

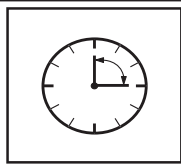
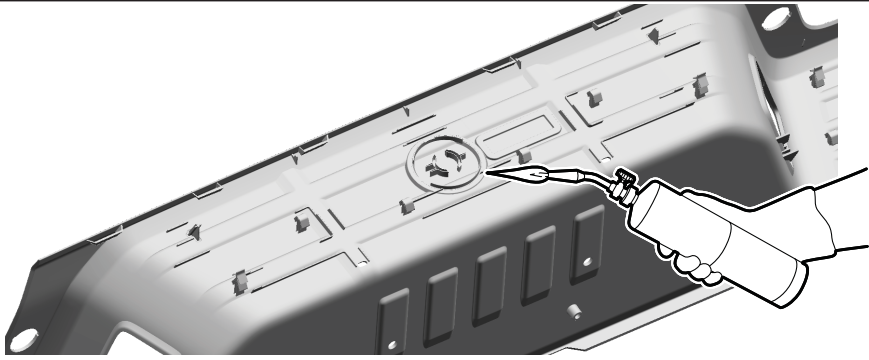

- (EN) Using a propane torch, allow the tip of the flame to contact the bumper cover step pad and cap, always in a quick back and forth motion, never stopping, for 2 seconds.
- (E) Con una antorcha de propano, permita que la punta de la llama entre en contacto con el protector del estribo de la cubierta del parachoques y la tapa, siempre en un movimiento hacia adelante y atrás de manera rápida, sin dejar de moverse y por 2 segundos.
- (F) Avec un chalumeau au propane, laissez la pointe de la flamme entrer en contact avec le marchepied de couvercle du pare-chocs et le capuchon, toujours par un va-et-vient rapide sans s'arrêter, pendant 2 secondes.

15

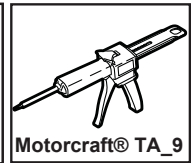
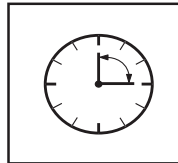
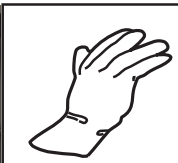

- (EN) Apply a 1/8 in (3 mm) bead of Motorcraft® TA-9 adhesive where the cap and the bumper cover meet. Do not twist or bend the bumper cover step pad. Allow the adhesive to cure for 90 minutes before reinstalling the bumper cover step pad.
- (E) Aplique un cordón de 1/8 in (3 mm) del adhesivo Motorcraft® TA-9 en donde se tocan la tapa y la cubierta del parachoques. No gire ni doble el protector del estribo de la cubierta del parachoques. Permita que el adhesivo se cure por 90 minutos antes de reinstalar el protector del estribo de la cubierta del parachoques.
- (F) Appliquer un cordon de 3 mm (1/8 po) d'adhésif Motorcraft® TA-9 à l'endroit où le capuchon et le couvercle de pare-chocs se touchent. Ne pas tordre ou déformer le marchepied de couvercle du pare-chocs. Laisser sécher l'adhésif pendant 90 minutes avant de reposer le marchepied de couvercle du pare-chocs.

16

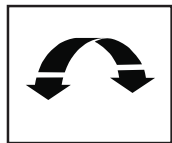
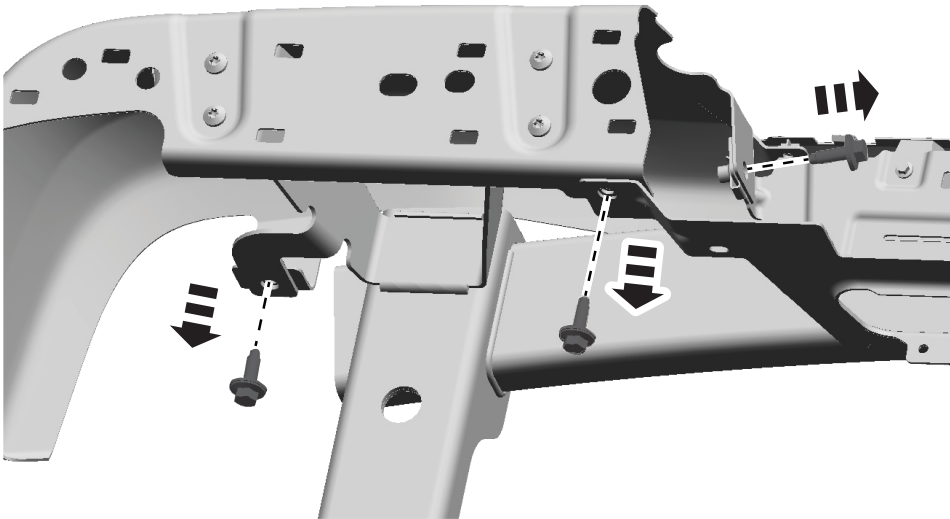

17

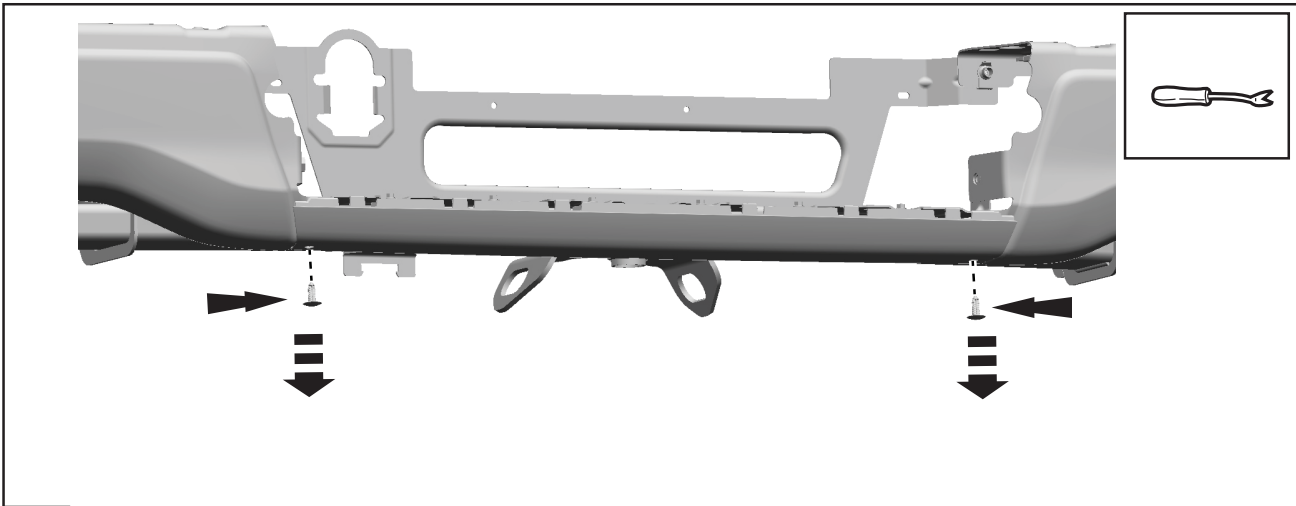

18

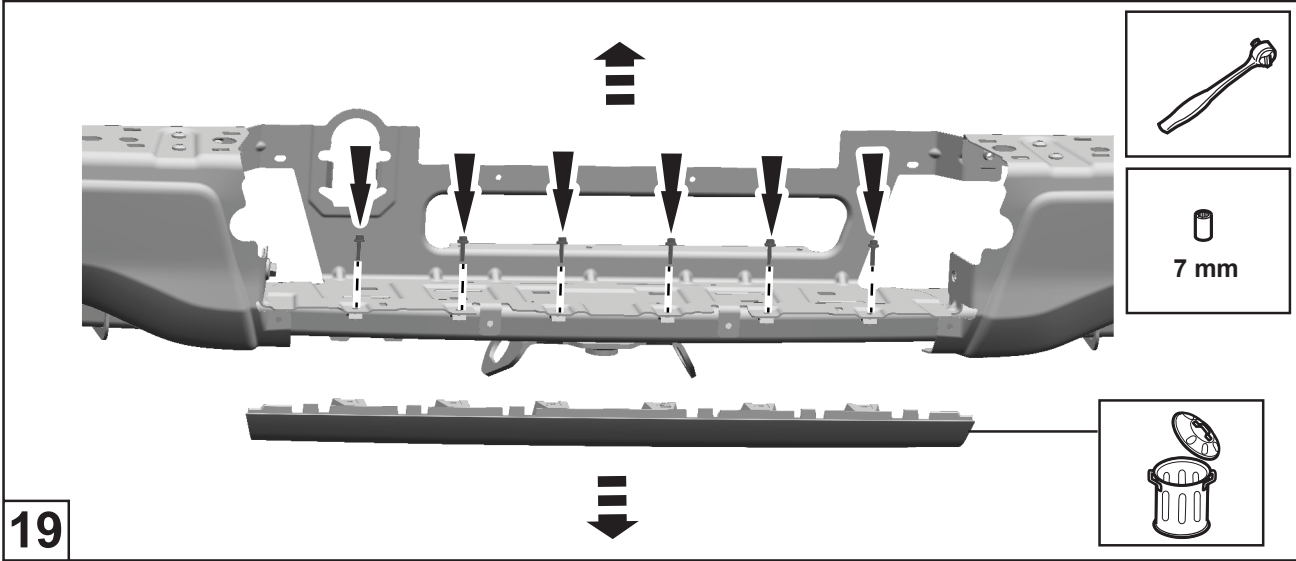

19

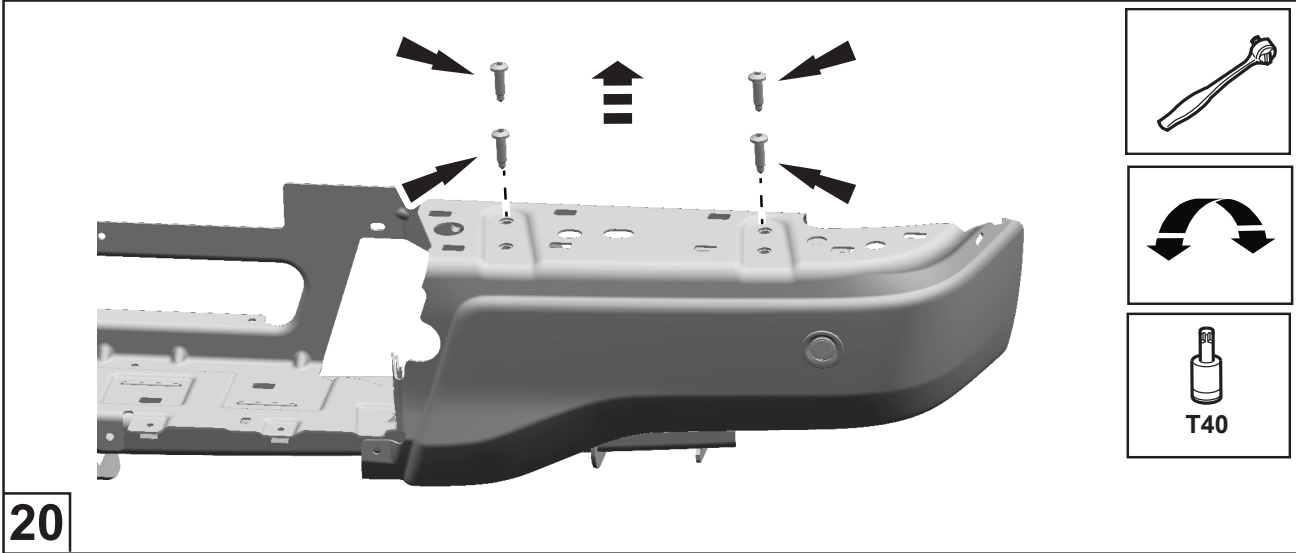

20

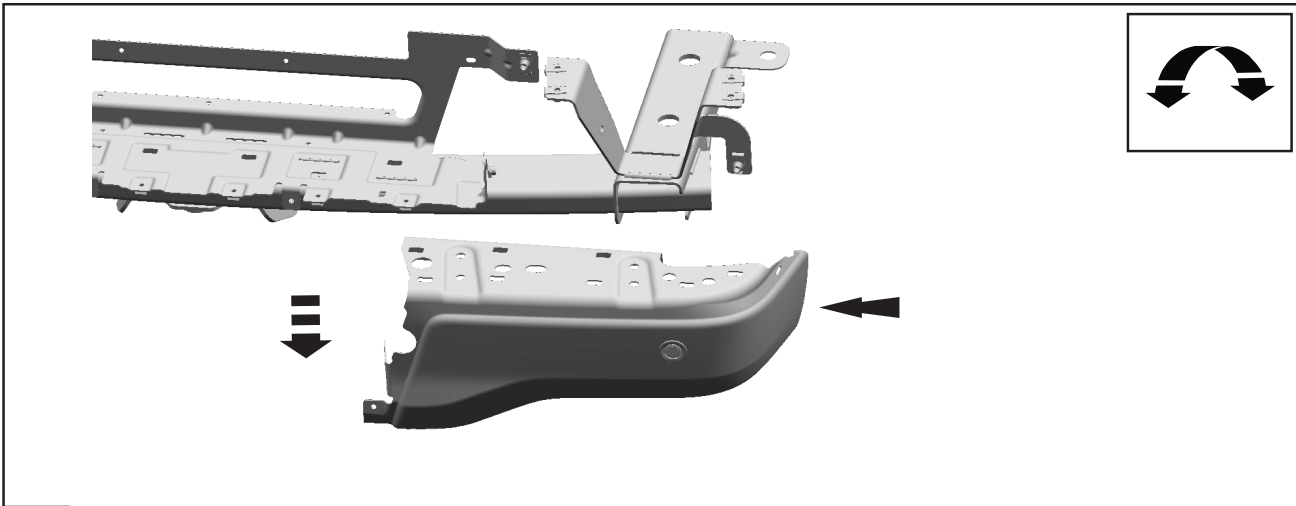

21

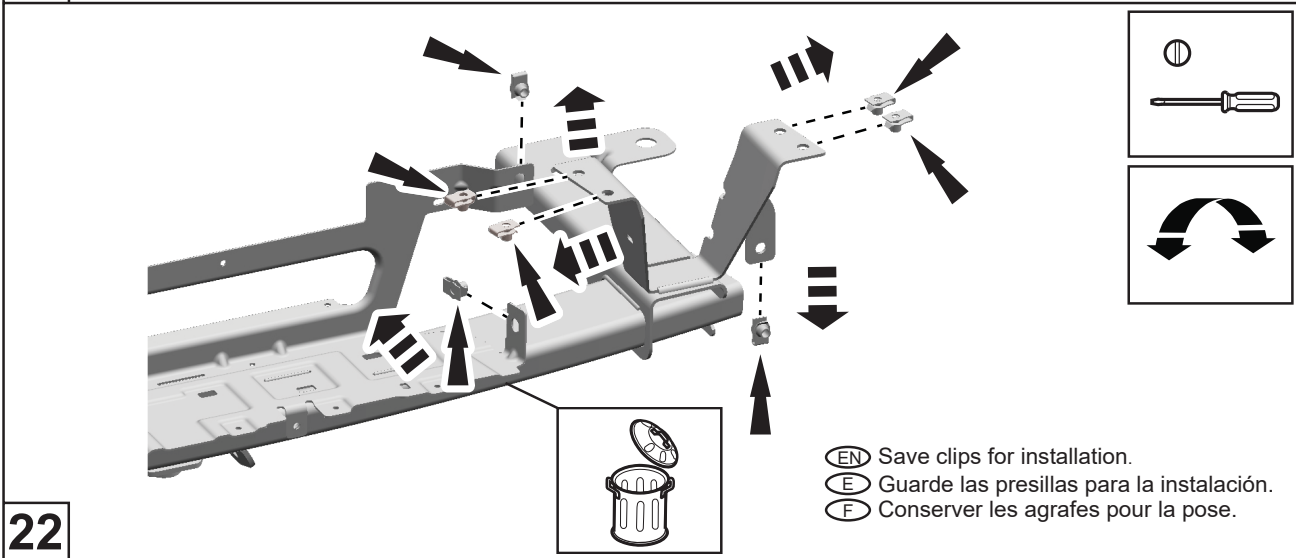

22

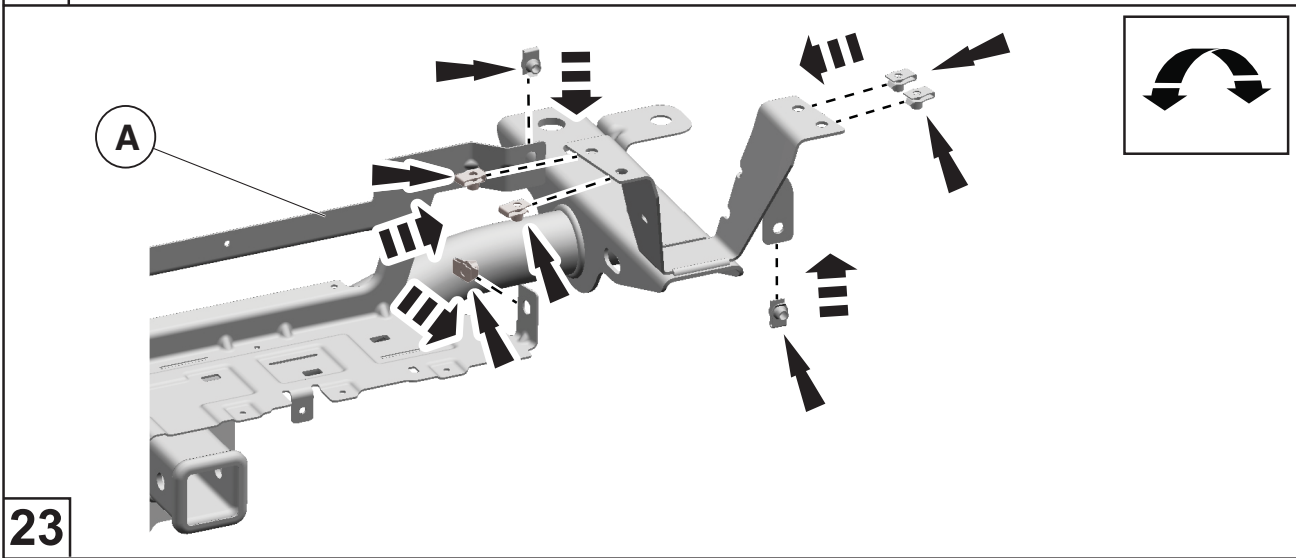

23

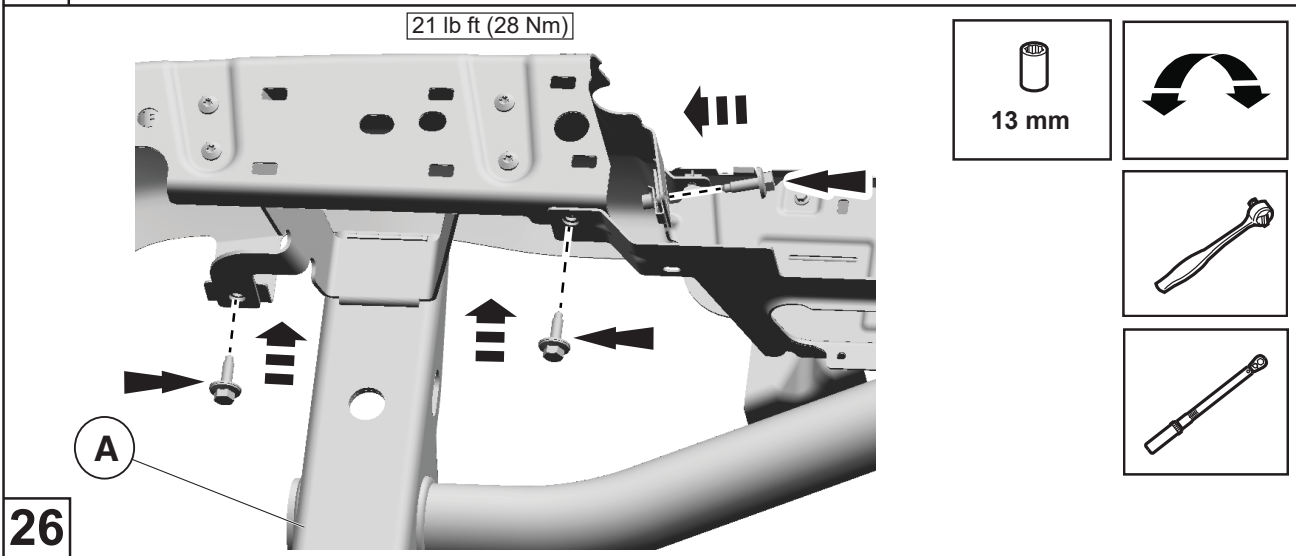
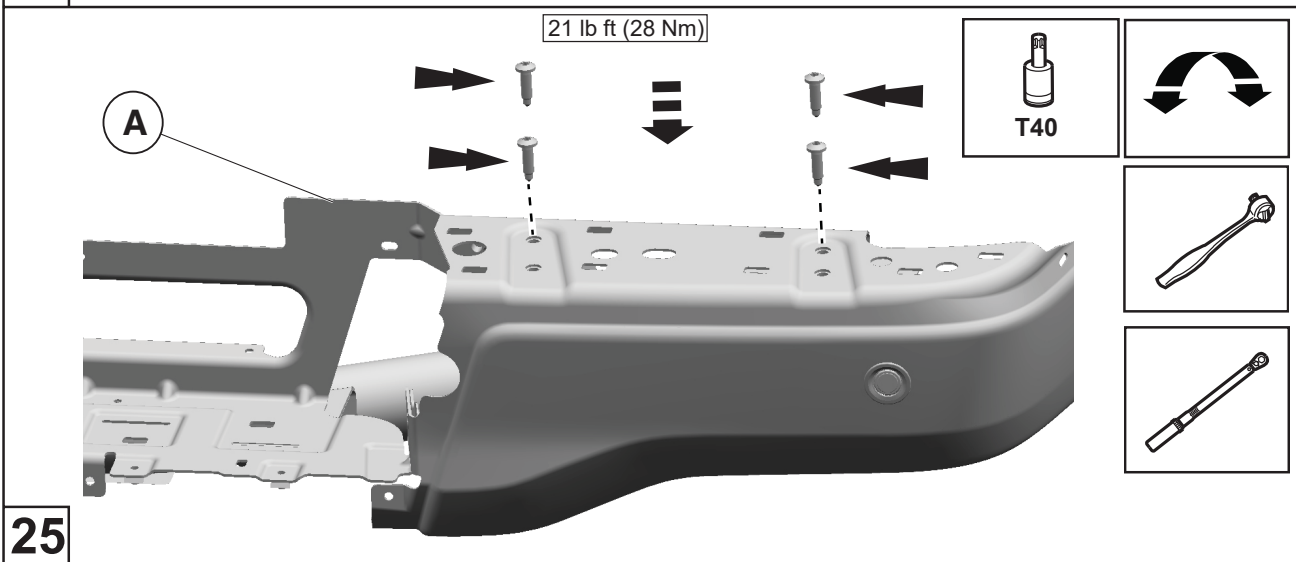
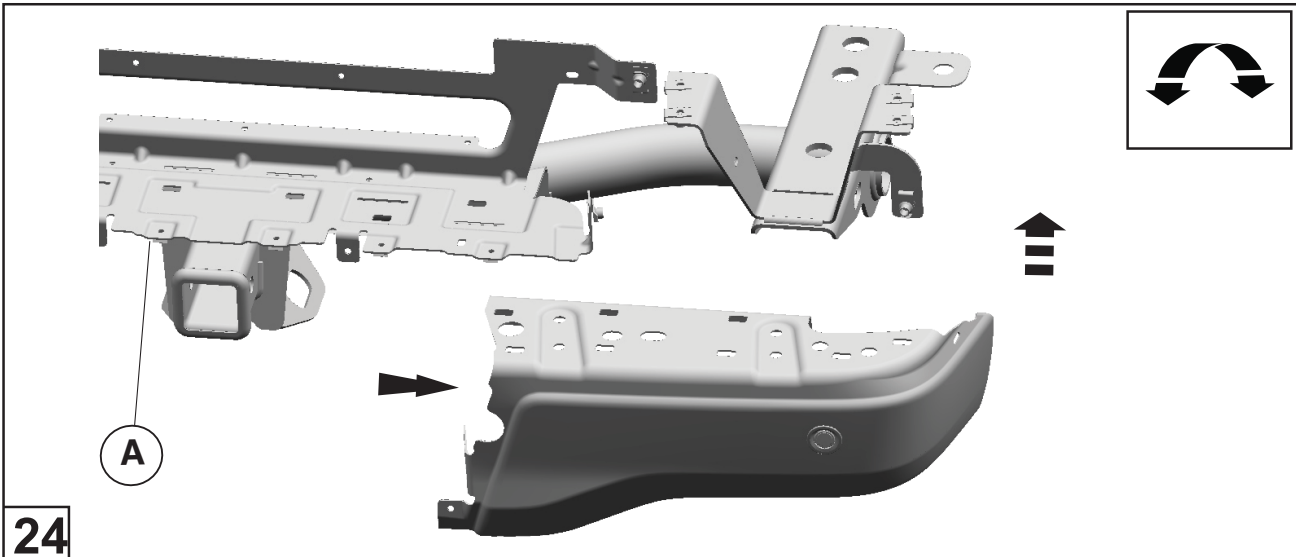

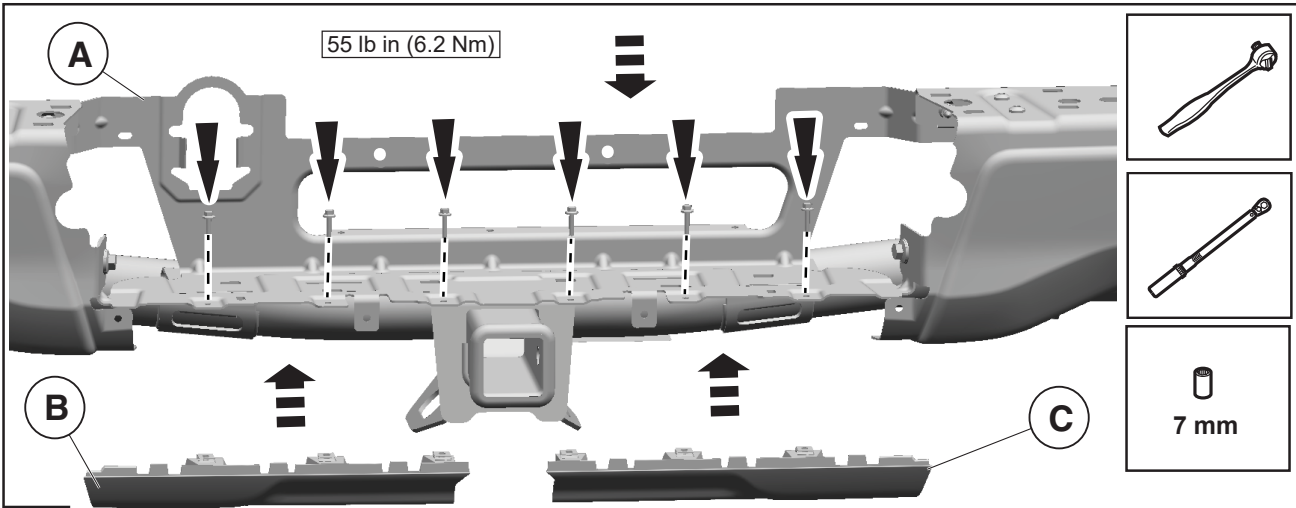

27

- (EN) Align the Christmas tree retainers. If retainers don't seat correctly and or bend, step pad will not seat fully.
- (E) Alinee los retenes cónicos. Si los retenes no se sientan de manera correcta o se doblan, el protector del estribo no se sentará correctamente.
- (F) Aligner les retenues en arêtes de poisson. Si les retenues ne se fixent pas correctement et/ou se tordent, le marche pied ne s'ajuste pas complètement.

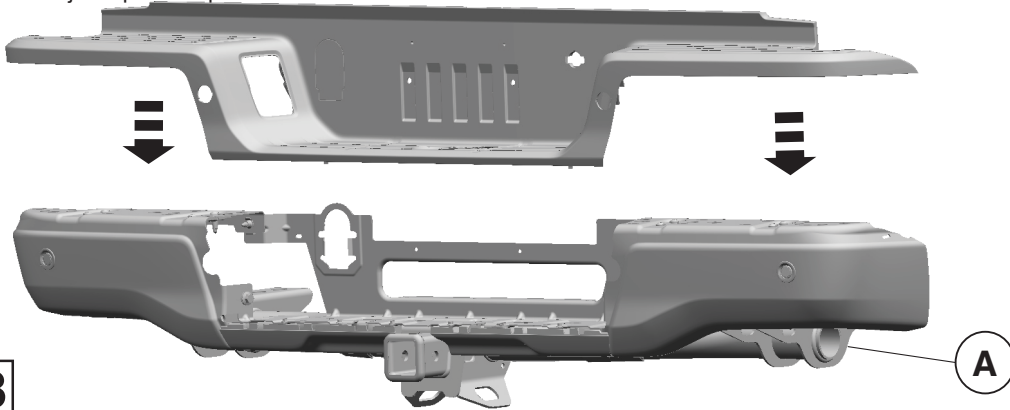

28

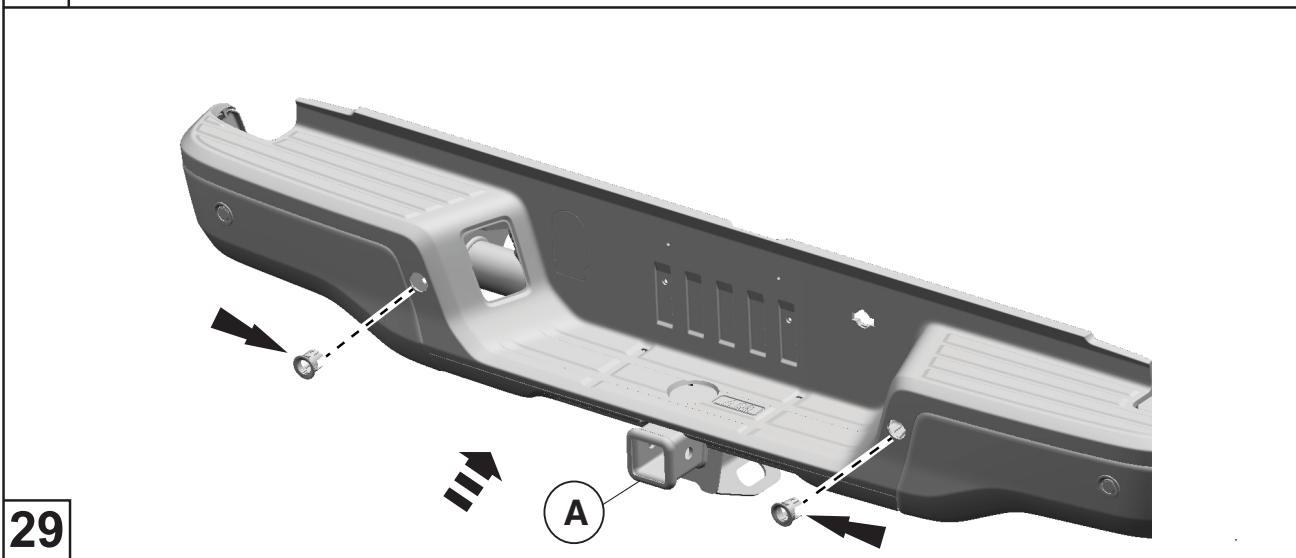

29

- (EN) Use hand pressure to seat the trim pieces. Ensure no gaps are present.
- (E) Utilice presión manual para asentar las partes de las molduras. Asegúrese de que no haya separaciones
- (F) Appuyer avec les mains pour aligner les pièces de garniture. S'assurer qu'aucun écartement n'est présent.

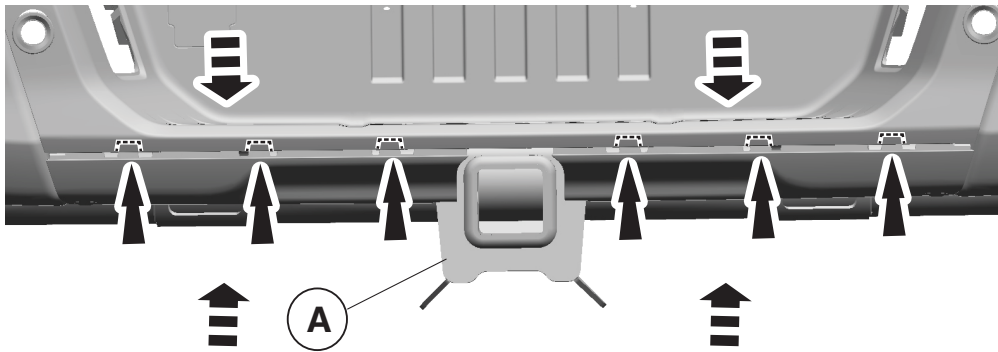

30

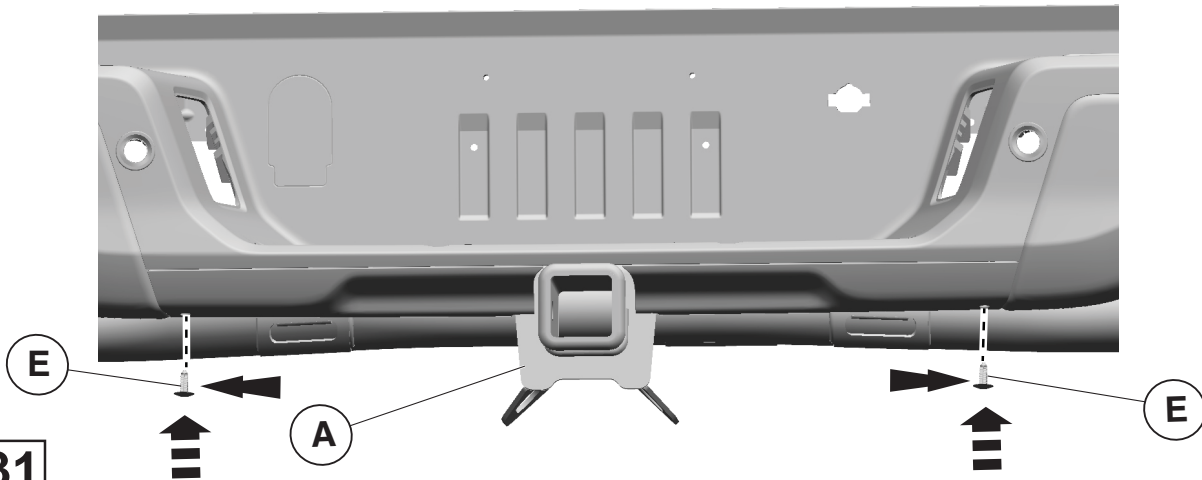

31

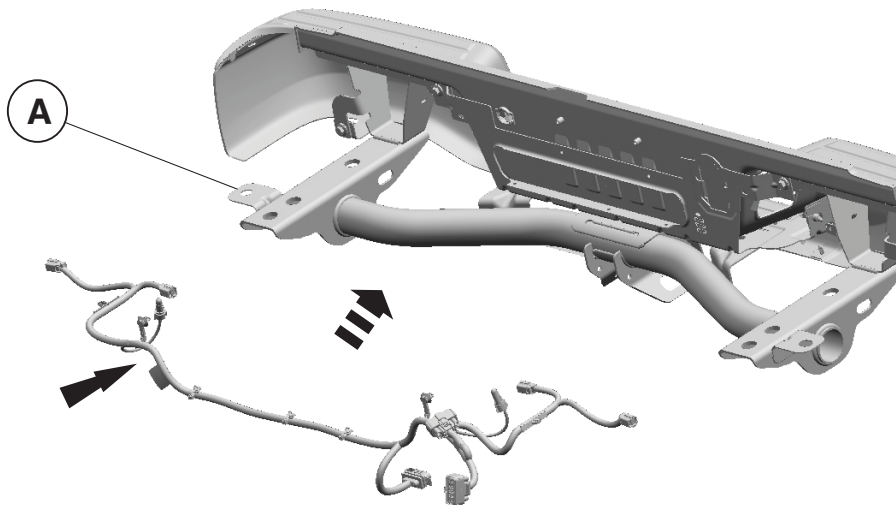

32



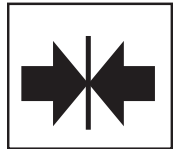
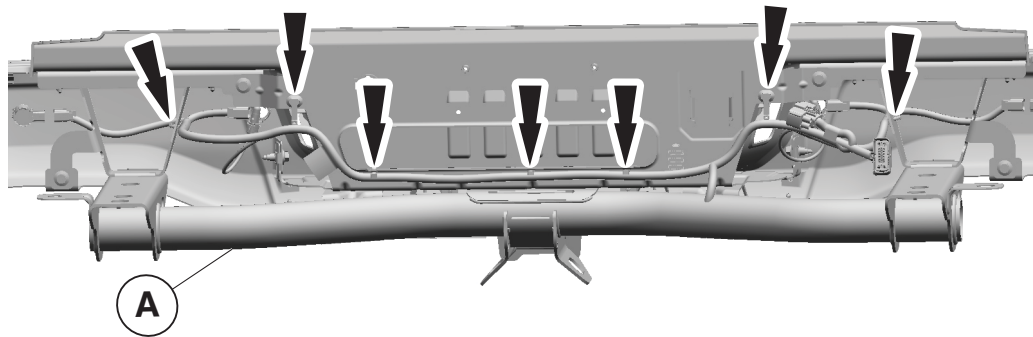

- (EN) If equipped, secure the 4 pin connector to the wire harness using tie-straps.
- (E) De estar equipado, asegure el conector de 4 clavijas al mazo de cables con precintos.
- (F) Le cas échéant, fixer le connecteur 4 broches au faisceau de câbles avec des sangles.

33

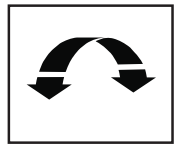

34

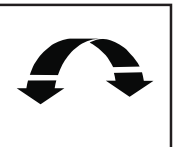
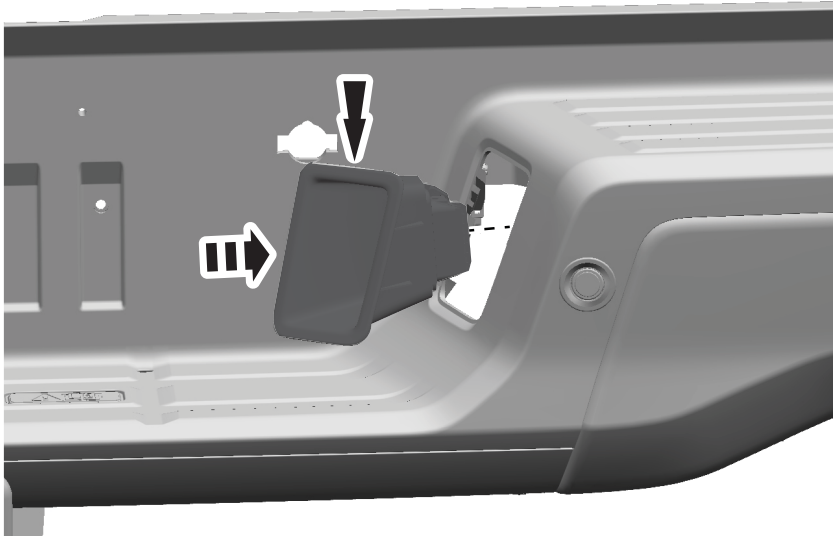

35



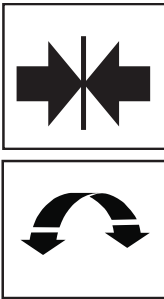
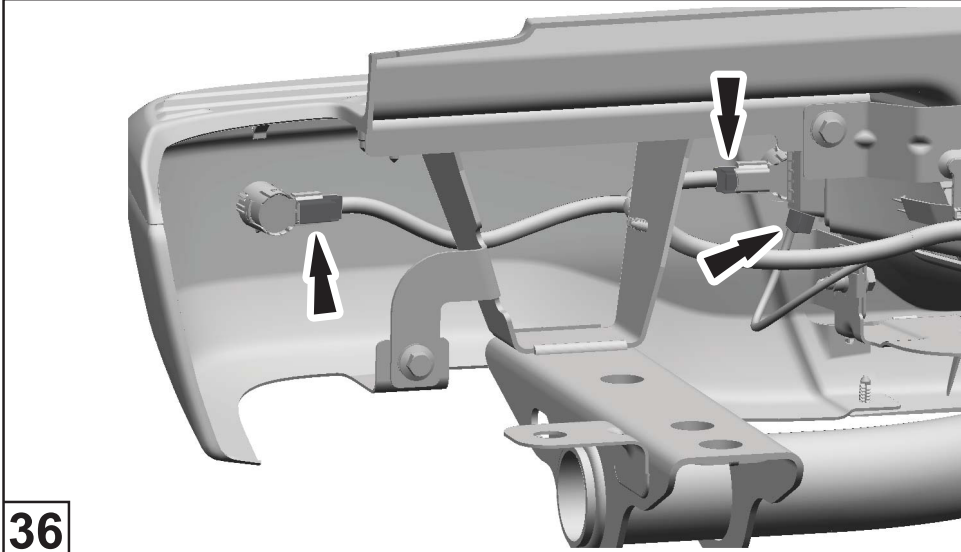

36

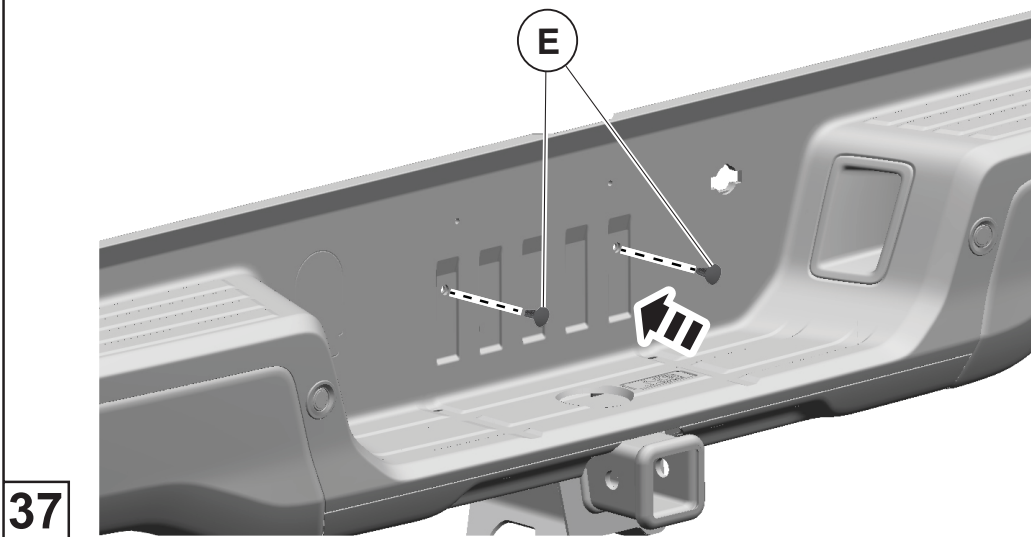

37

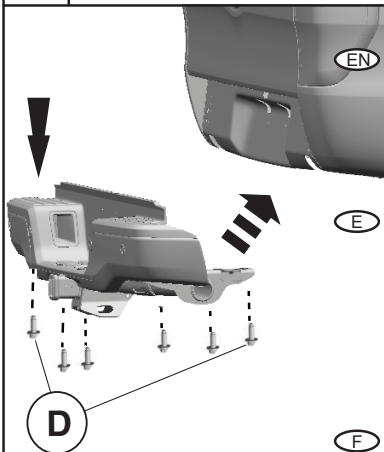

(EN) Install the rear bumper assembly using (4) bolts saved from removal in addition to the (2) bolts included in the kit. Carry out the azimuth and elevation system checks. Refer to: Azimuth System Check (413-13A Parking Aid, General Procedures). Refer to: Elevation System Check (413-13A Parking Aid, General Procedures). If any sensor fails the system checks, diagnose the sensor fault. Refer to: Parking Aid (413-13A Parking Aid, Diagnosis and Testing).

(E) Instale el conjunto del parachoques trasero con los (4) pernos que guardó cuando los quitó, además de los (2) pernos incluidos en el kit. Realice los controles del sistema azimutal y de elevación. Consulte: Control del sistema azimutal (413-13A Asistencia en el estacionamiento, procedimientos generales). Consulte: Control del sistema de elevación (413-13A Asistencia en el estacionamiento, procedimientos generales). Si alguno de los sensores no pasa los controles del sistema, realice un diagnóstico de fallas de los sensores. Consulte: Asistencia en el estacionamiento (413-13A Asistencia en el estacionamiento, diagnósticos y pruebas).

(F) Installer l'ensemble de pare-chocs arrière en utilisant (4) boulons conservés à la dépose en plus des (2) boulons inclus dans le jeu de pièces. Effectuer les contrôles du système d'azimut et d'élévation.

Voir : Contrôle du système d'azimut (413-13A Assistance au stationnement, Procédures générales). Voir : Contrôle du système d'élévation (413-13A Assistance au stationnement, Procédures générales). Si n'importe quel capteur échoue lors des contrôles du système, diagnostiquer le défaut de ce capteur. Voir : Assistance au stationnement (413-13A Assistance au stationnement, Diagnostic et test).

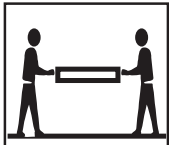

38

148 lb ft (200 Nm)