

Front Drive Halfshafts

Inspection and Verification

NOTE: New front wheel drive halfshafts should not be installed unless disassembly and inspection reveals unusual wear.

1. Inspect front wheel driveshaft joint boots for evidence of cracks, tears or splits.

NOTE: While inspecting the front wheel driveshaft CV joint boots, watch for indentations (dimples) in the boot convolutions. If an indentation is observed, it must be removed.

2. Inspect the underbody for any indication of grease splatter in the vicinity of the front wheel driveshaft CV joint boots outboard and inboard locations, which is an indication of front wheel driveshaft CV joint boot and/or front wheel driveshaft CV joint boot clamp damage.
3. Inspect for inboard CV joint stub shaft pilot bearing housing seal leakage at the front wheel driveshaft CV joint.
4. Make sure front axle wheel hub retainer is the correct prevailing torque type.
5. If the concerns remain after the inspection, determine the symptoms and go to the Symptom Chart. For additional Noise, Vibration and Harshness (NVH). REFER to: [Noise, Vibration and Harshness \(NVH\)](#) (100-04 Noise, Vibration and Harshness, Diagnosis and Testing).

Symptom Chart

Condition	Possible Sources	Actions
Axle howling or whine – front or rear axle	<ul style="list-style-type: none"> • Damaged or worn wheel hub bearings 	<ul style="list-style-type: none"> • CHECK for abnormal wheel hub bearing play or roughness. REFER to: Front Wheel Bearing and Wheel Hub (204-01A Front Suspension - RWD, Removal and Installation).
Driveline clunk - loud clunk when shifting from REVERSE to DRIVE	<ul style="list-style-type: none"> • Damaged or worn <u>CV</u> joints 	<ul style="list-style-type: none"> • INSPECT the <u>CV</u> joints for wear or damage. INSTALL a new halfshaft or driveshaft as necessary. REFER to: Front Halfshaft LH (205-04 Front Drive Halfshafts, Removal and Installation). REFER to: Front Halfshaft RH (205-04 Front Drive Halfshafts, Removal and Installation).
	<ul style="list-style-type: none"> • Loose hub nut 	<ul style="list-style-type: none"> • CHECK the torque on the hub

		<p>nut. REPLACE the hub nut if the torque is not at specification. For front hub nuts.</p> <p>REFER to: Front Halfshaft LH (205-04 Front Drive Halfshafts, Removal and Installation).</p> <p>REFER to: Front Halfshaft RH (205-04 Front Drive Halfshafts, Removal and Installation).</p>
Driveline clunk <u>FWD</u> (vehicles) — occurs during acceleration or from cruise to coast/deceleration	<ul style="list-style-type: none"> • Damaged or worn <u>CV</u> joints 	<ul style="list-style-type: none"> • INSPECT the inner <u>CV</u> joint and boot. INSTALL a new halfshaft as necessary. REFER to: Front Halfshaft LH (205-04 Front Drive Halfshafts, Removal and Installation). REFER to: Front Halfshaft RH (205-04 Front Drive Halfshafts, Removal and Installation).
	<ul style="list-style-type: none"> • Loose hub nut 	<ul style="list-style-type: none"> • CHECK the torque on the hub nut. REPLACE the hub nut if the torque is not at specification. REFER to: Front Halfshaft LH (205-04 Front Drive Halfshafts, Removal and Installation). REFER to: Front Halfshaft RH (205-04 Front Drive Halfshafts, Removal and Installation).
Driveline clunk — occurs as the vehicle starts to move forward following a stop	<ul style="list-style-type: none"> • Loose hub nut 	<ul style="list-style-type: none"> • CHECK the torque on the hub nut. REPLACE the hub nut if the torque is not at specification. REFER to: Front Halfshaft LH (205-04 Front Drive Halfshafts, Removal and Installation). REFER to: Front Halfshaft RH (205-04 Front Drive Halfshafts, Removal and Installation).
Clicking, popping or grinding - occurs while the vehicle is turning	<ul style="list-style-type: none"> • Inadequate or contaminated lubrication in the <u>CV</u> joints 	<ul style="list-style-type: none"> • CHECK the <u>CV</u> boots and joints for wear or damage. INSTALL new components as necessary. REFER to: Front Halfshaft LH (205-04 Front Drive Halfshafts, Removal and Installation). REFER to: Front Halfshaft RH (205-04 Front Drive Halfshafts, Removal and Installation).
	<ul style="list-style-type: none"> • Another component contacting the halfshaft 	<ul style="list-style-type: none"> • CHECK the halfshafts and the area around the halfshafts. REPAIR as necessary.
Grunting — normally associated with a shudder experienced during acceleration from a complete stop	<ul style="list-style-type: none"> • Halfshaft <u>CV</u> joint binding 	<ul style="list-style-type: none"> • CHECK the outer <u>CV</u> joint for correct seating into the hub. REPAIR as necessary. REFER to: Front Halfshaft LH (205-04 Front Drive Halfshafts, Removal and Installation).

		REFER to: Front Halfshaft RH (205-04 Front Drive Halfshafts, Removal and Installation).
Driveline vibration - occurs at cruising speeds	<ul style="list-style-type: none"> • Incorrectly seated <u>CV</u> joint in the wheel hub 	<ul style="list-style-type: none"> • CHECK the outer <u>CV</u> joint for correct seating into the hub. REPAIR as necessary. REFER to: Front Halfshaft LH (205-04 Front Drive Halfshafts, Removal and Installation). REFER to: Front Halfshaft RH (205-04 Front Drive Halfshafts, Removal and Installation). REFER to: Front Wheel Bearing and Wheel Hub (204-01A Front Suspension - RWD, Removal and Installation).

Copyright © 2019 Ford Motor Company

Front Halfshaft

Special Tool(s) / General Equipment

Flat Headed Screw Driver
Boot Clamp Pliers
Rubber Mallet
Puller

DISASSEMBLY

NOTE: LH side shown, RH side similar.

1. Remove the halfshaft.
Refer to: [Front Halfshaft LH](#) (205-04 Front Drive Halfshafts, Removal and Installation).
Refer to: [Front Halfshaft RH](#) (205-04 Front Drive Halfshafts, Removal and Installation).
2. Remove and discard the inner CV boot clamp.

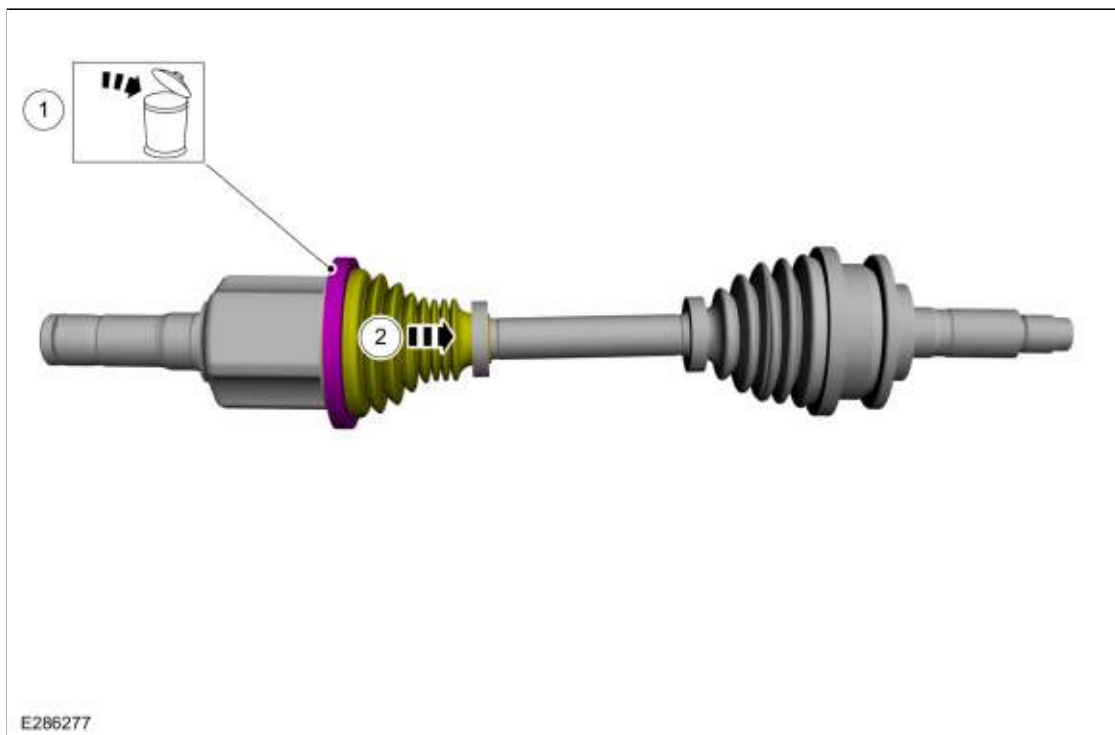

3. Remove the inner CV joint housing.

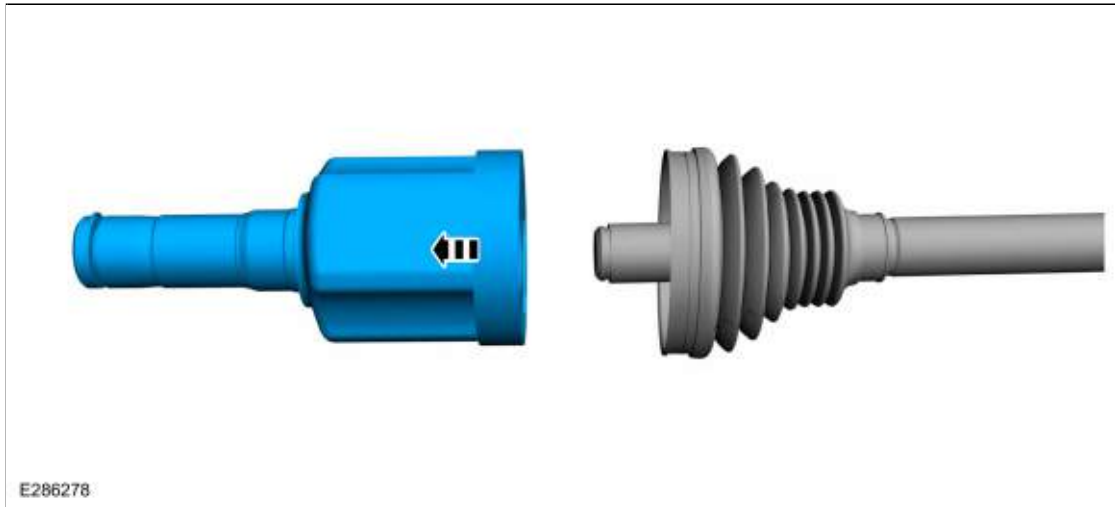

4. Remove and discard the small clamp and remove the CV joint boot.

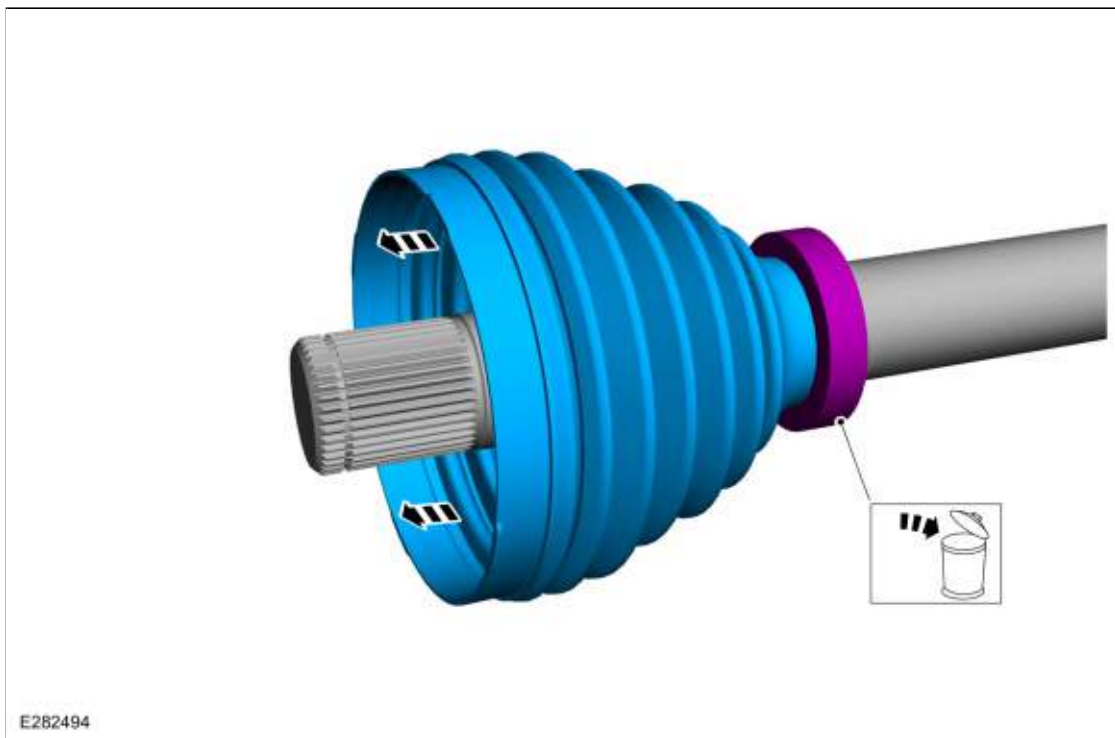

5. Remove and discard the inner CV housing retaining ring.

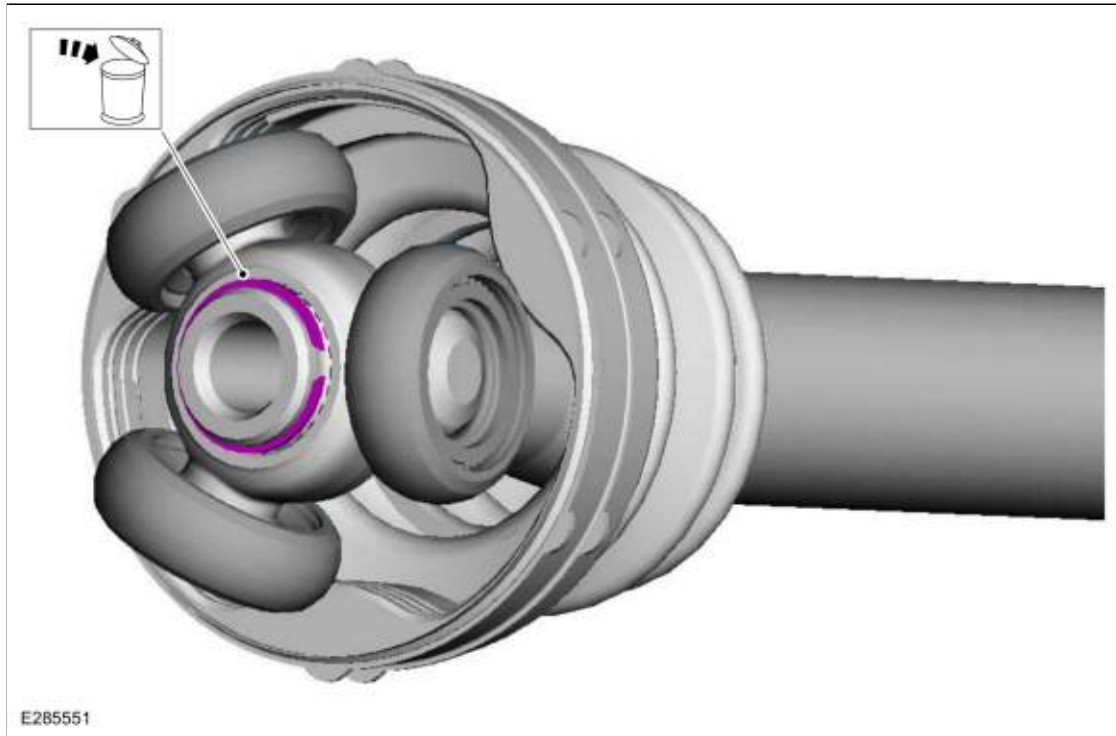

6. **NOTE:** Make sure that the CV joint cage bearings not get damaged.

Using general equipment, remove the CV joint cage.
Use the General Equipment: Puller





- 7.
1. Remove and discard the CV joint boot clamps.
 2. Remove the CV joint boot.

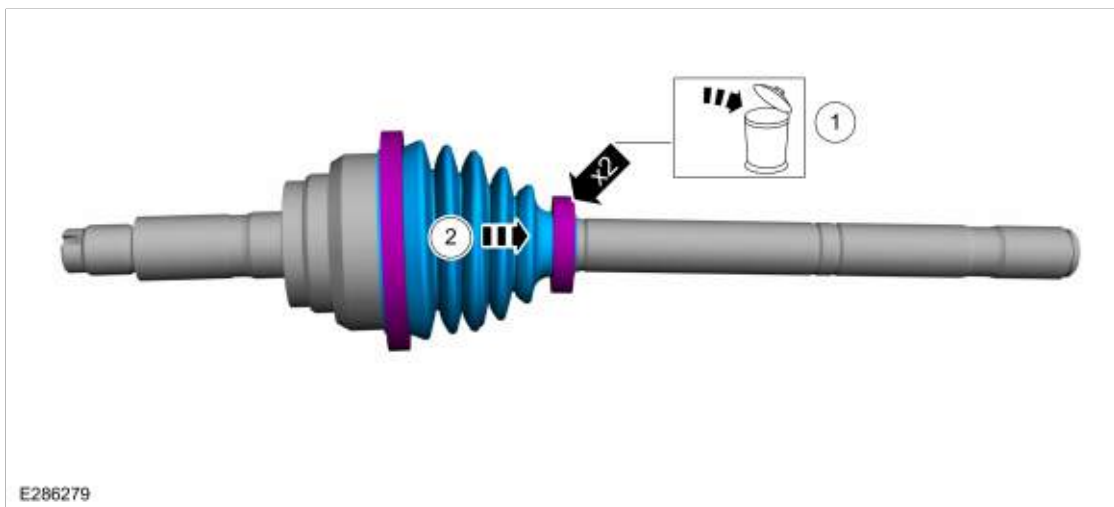

ASSEMBLY

1. **NOTICE:** Outboard joint to shaft connection are not serviceable.

1. Clean and inspect the CV joint cage.
2. Inspect the outer CV joint housing for damage.
3. **NOTE:** Use the grease from the sachet evenly in the CV joint boot and housing.

Apply the grease from the sachet evenly in the CV joint boot and housing.

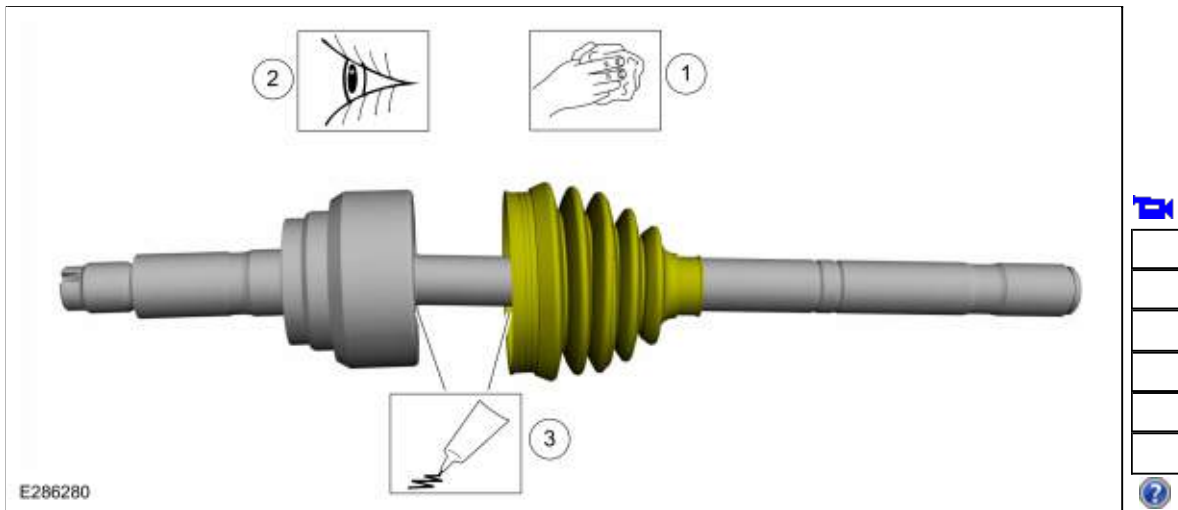

2.

Install the CV joint housing.

1. **NOTE:** When installing the CV joint housing, insert a small flat blade screwdriver under the CV joint boot seat to allow air to escape.

Using a flat blade screw driver to allow air to escape, install the CV joint housing.

Use the General Equipment: Flat Headed Screw Driver

2. Using boot clamp pliers, install the new small CV joint boot clamp.
Use the General Equipment: Boot Clamp Pliers
Torque: 133 lb.in (15 Nm)
3. Using boot clamp pliers, install the new large CV joint boot clamp.
Use the General Equipment: Boot Clamp Pliers
Torque: 15 lb.ft (21 Nm)



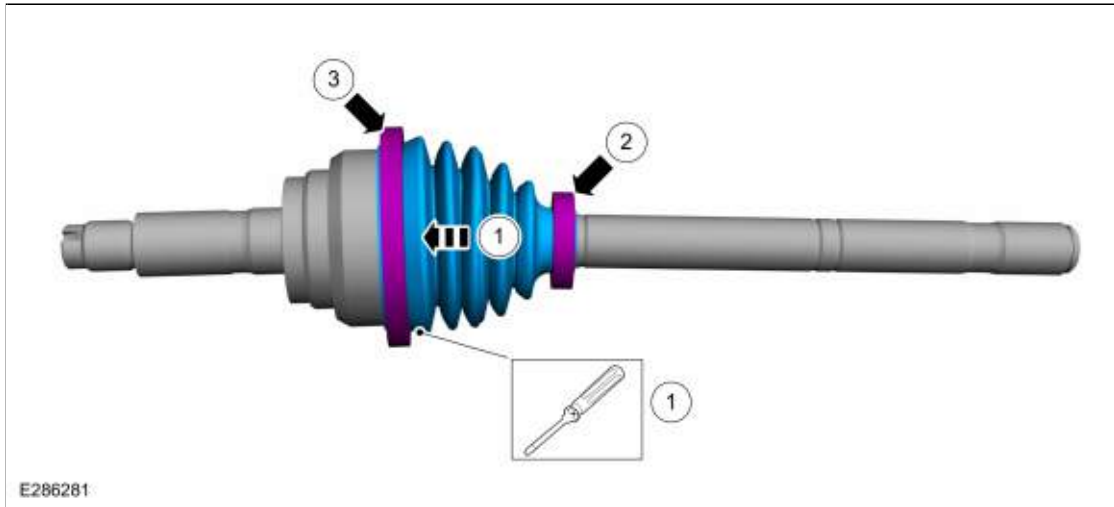

3. Using boot clamp pliers, install the new CV joint boot and the new small CV joint boot clamp. Use the General Equipment: Boot Clamp Pliers
Torque: 133 lb.in (15 Nm)

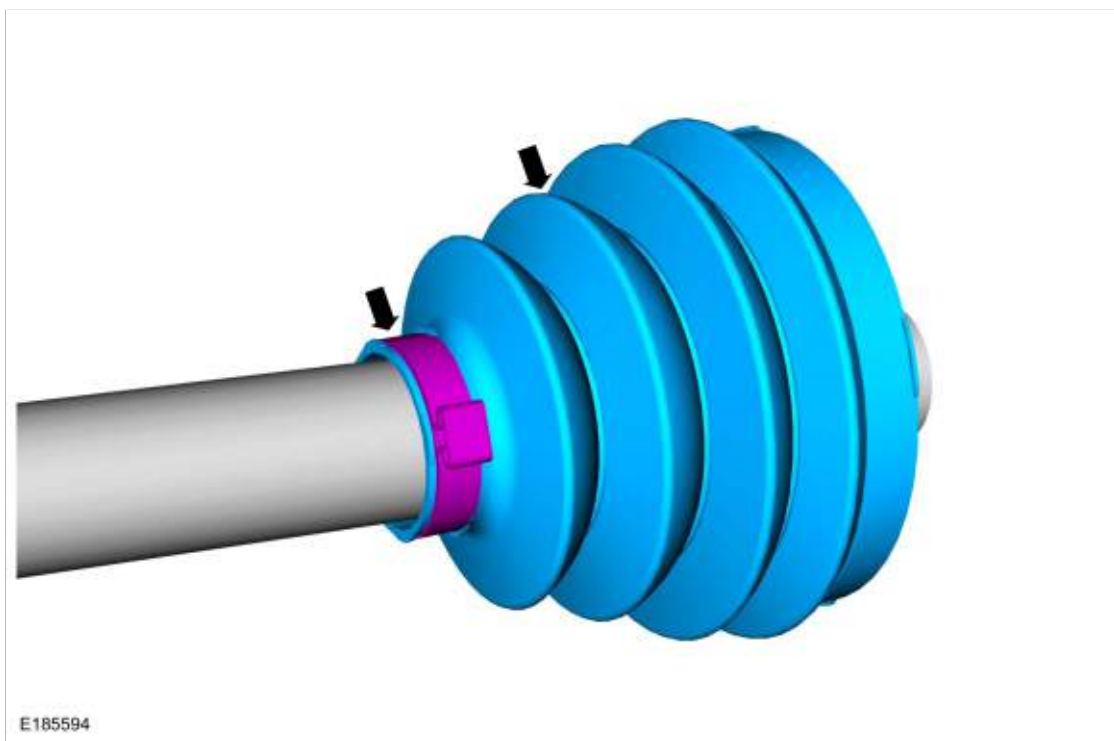

4. **NOTICE:** Install the CV joint cage with the chamfered bore facing down over the shaft or damage to CV joint cage may occur.

NOTE: Clean and inspect the CV joint cage.

NOTE: The CV joint cage is a snug fit and may need to be tapped on with a soft face mallet.

Using a soft face mallet, install the CV joint cage.
Use the General Equipment: Rubber Mallet

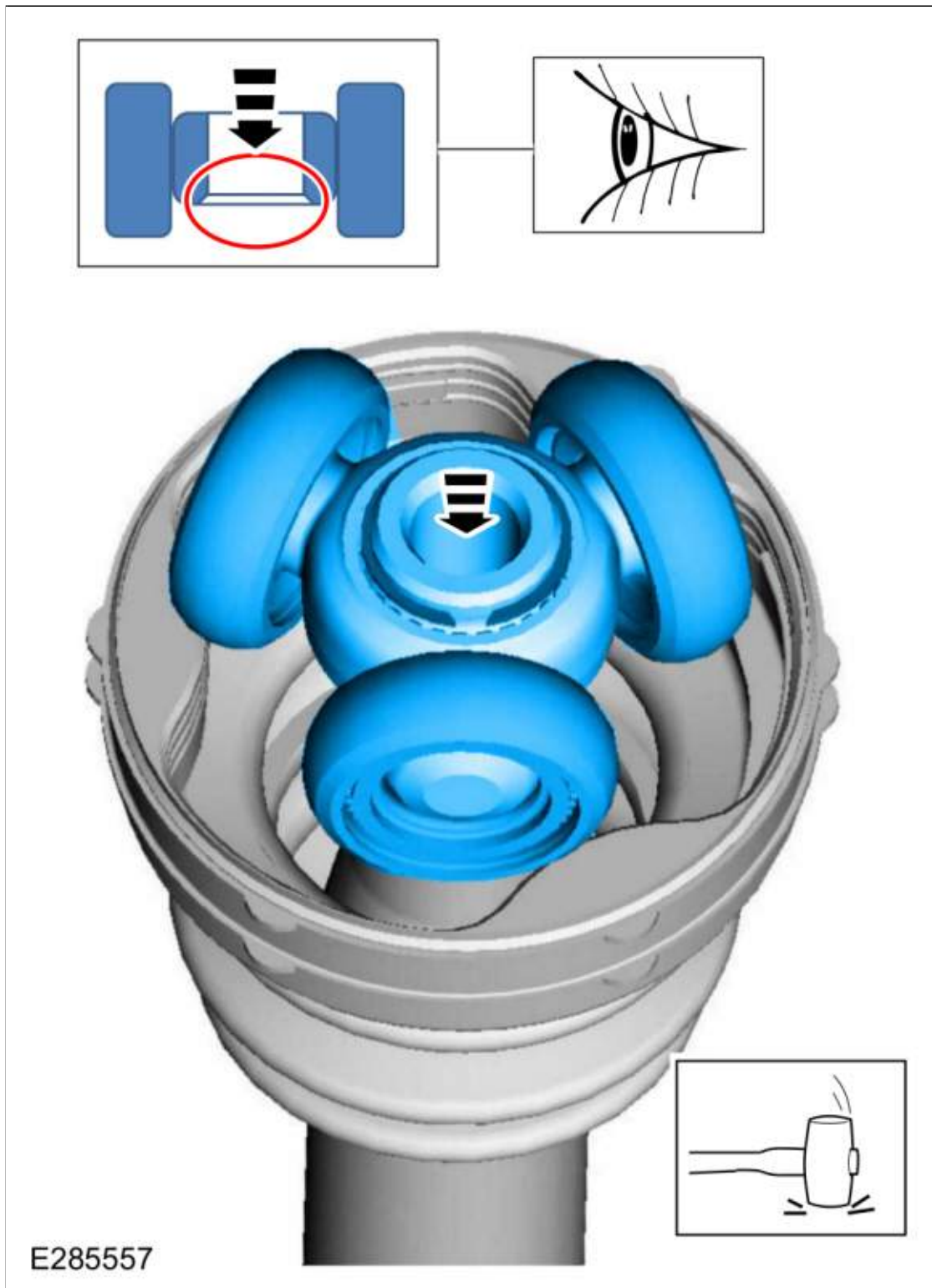

5. Install the new CV joint cage circlip.

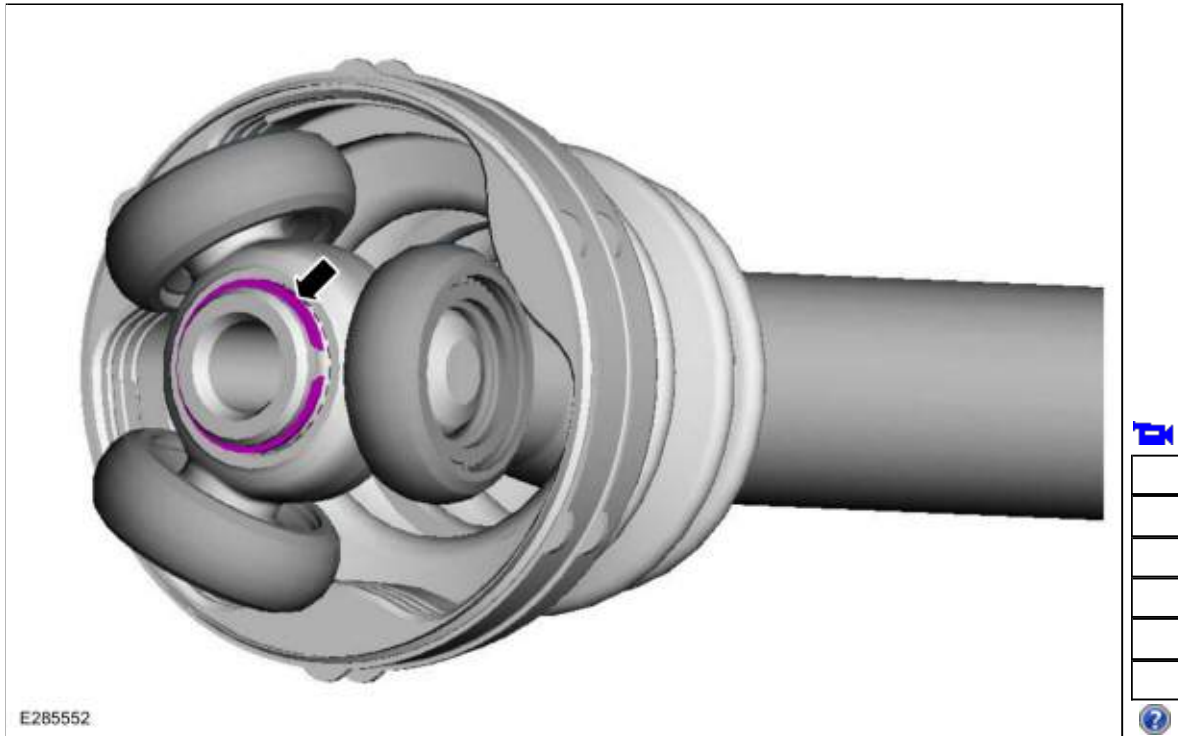

6. **NOTE:** Use the grease provided with the boot service kit.

Apply the grease from the sachet evenly in the CV joint boot and housing.

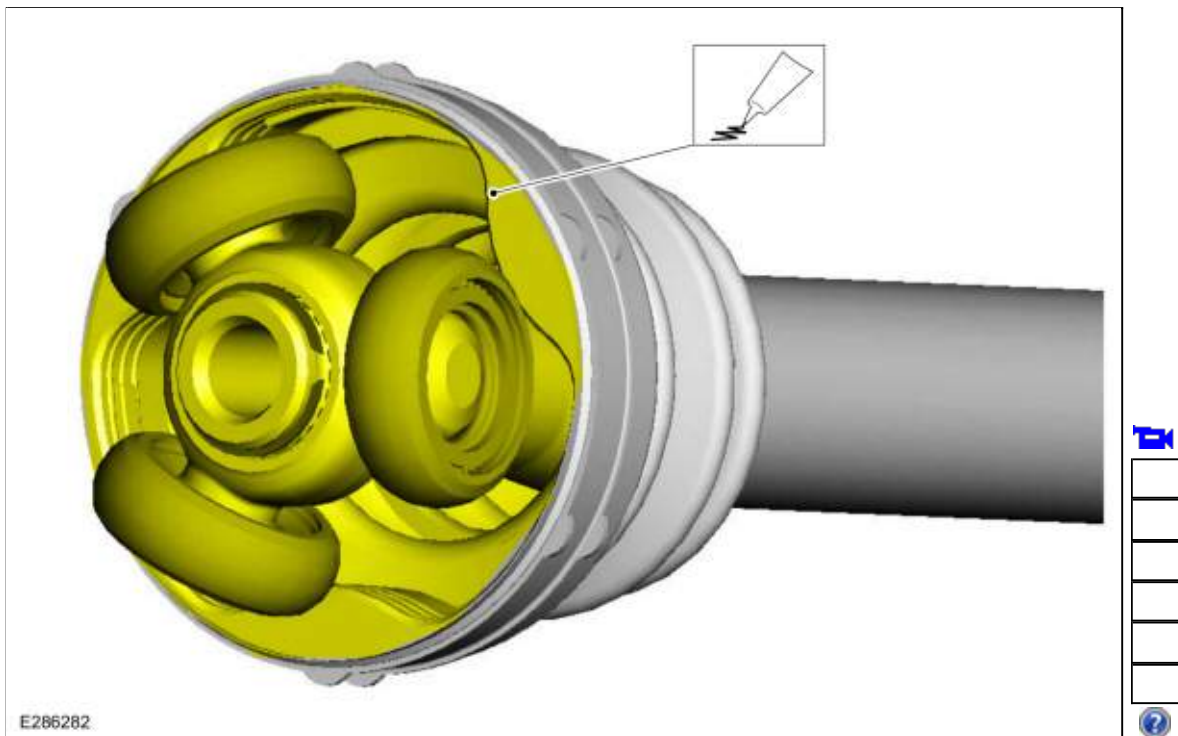

7. **NOTE:** When installing the CV joint housing, insert a small flat blade screwdriver under the CV joint boot seat to allow air to escape.

Install the inner CV housing and the new inner CV housing retaining ring.

1. Using a flat blade screw driver to allow air to escape, install the CV joint housing.
Use the General Equipment: Flat Headed Screw Driver
2. Using boot clamp pliers, install the new large CV joint boot clamp.
Use the General Equipment: Boot Clamp Pliers
Torque: 15 lb.ft (21 Nm)

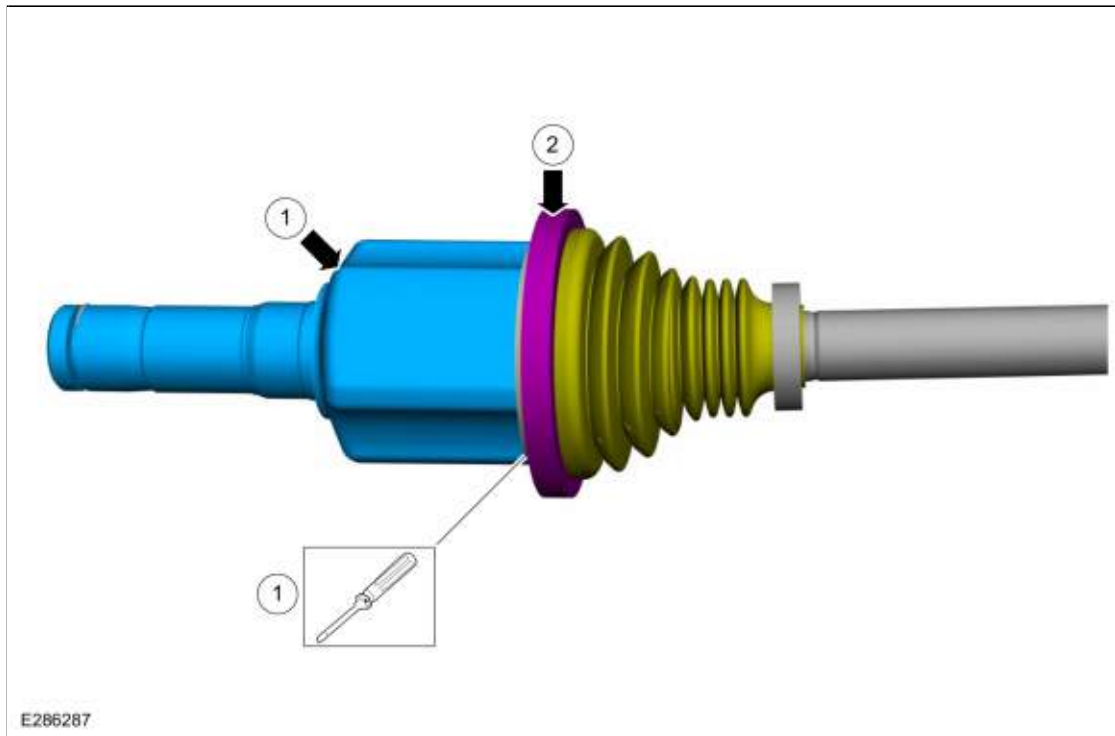

8. Install the halfshaft.

Refer to: [Front Halfshaft LH](#) (205-04 Front Drive Halfshafts, Removal and Installation).
Refer to: [Front Halfshaft RH](#) (205-04 Front Drive Halfshafts, Removal and Installation).

Front Halfshaft LH
Special Tool(s) / General Equipment

 <p data-bbox="305 653 370 674">E225294</p>	<p data-bbox="386 485 495 512">205-1047</p> <p data-bbox="386 514 662 541">Protector, Halfshaft Seal</p>
Tire Lever	

Removal

NOTICE: Do not hold the halfshaft by the CV joint.

NOTICE: The inner constant velocity (CV) joint must not be bent more than 18°.

NOTE: Removal steps in this procedure may contain installation details.

1. Drain the front differential.
Refer to: [Differential Draining and Filling](#) (205-03 Front Drive Axle/Differential, General Procedures).
2. Remove the wheel knuckle.
Refer to: [Wheel Knuckle](#) (204-01B Front Suspension - 4WD, Removal and Installation).
3. **NOTE:** Use care to not cause damage to the components.

Remove the front halfshaft LH.
Use the General Equipment: Tire Lever



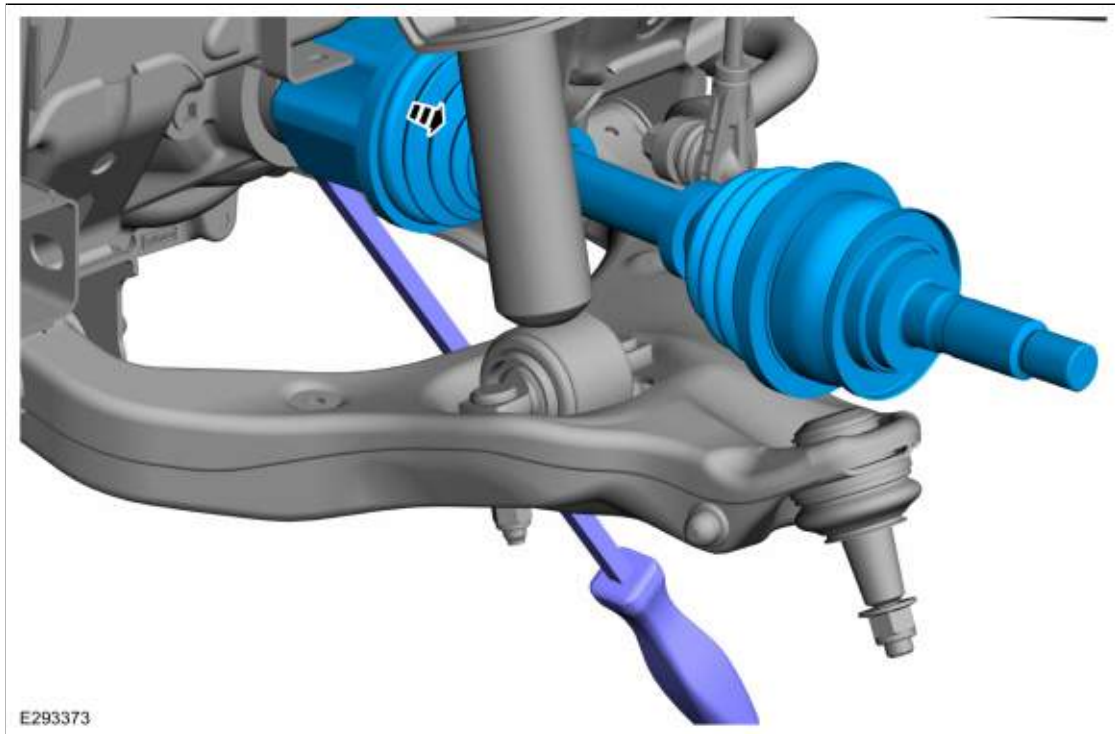

4.

1. Remove and discard the circlip.
2. Clean the inner and outer halfshaft ends.
3. Inspect the inner and outer halfshaft ends.

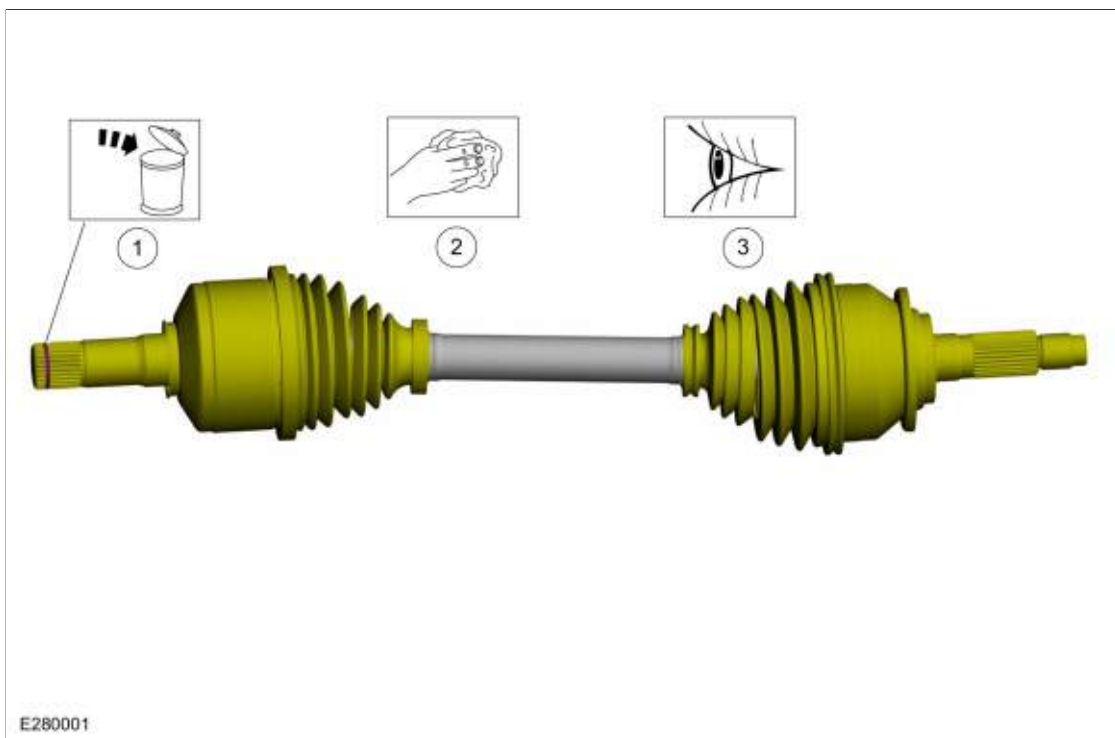

5.

Install Special Service Tool: [205-1047 Protector, Halfshaft Seal](#).

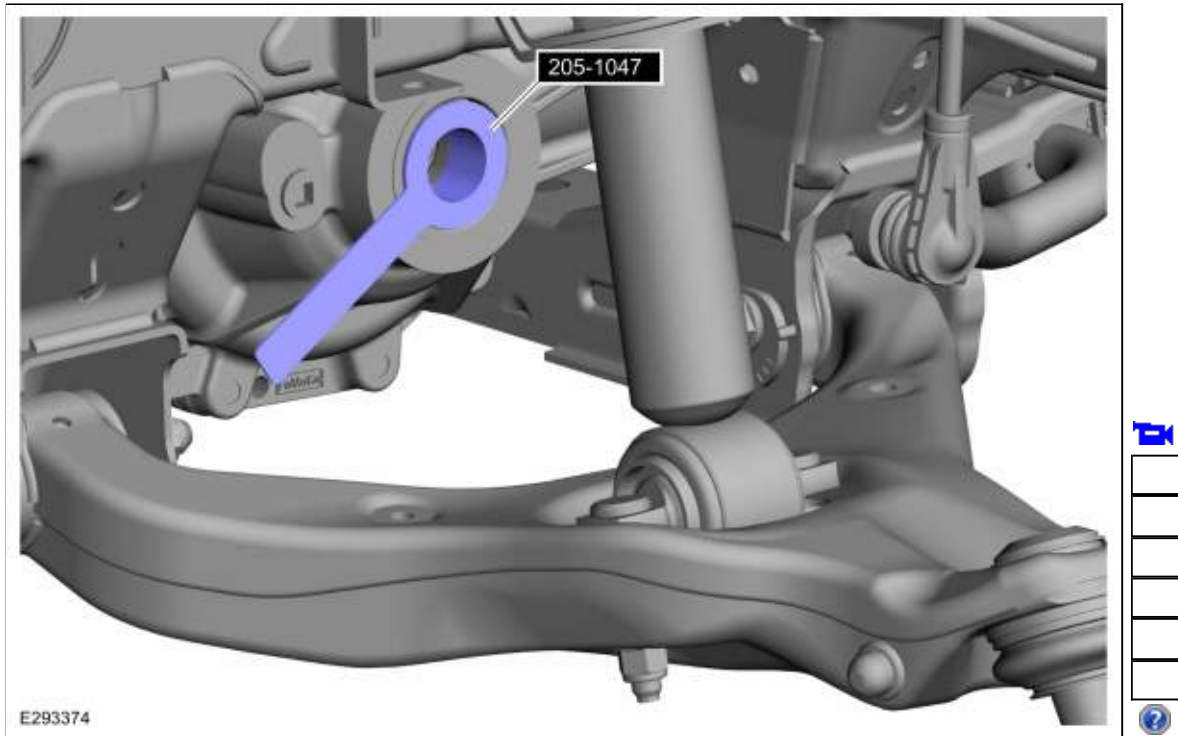

Installation

1. **NOTICE:** Take extra care not to damage the seal.

NOTE: Make sure that a new component is installed.

Remove the halfshaft seal protector before completely installing the halfshaft.
Remove Special Service Tool: [205-1047 Protector, Halfshaft Seal](#).



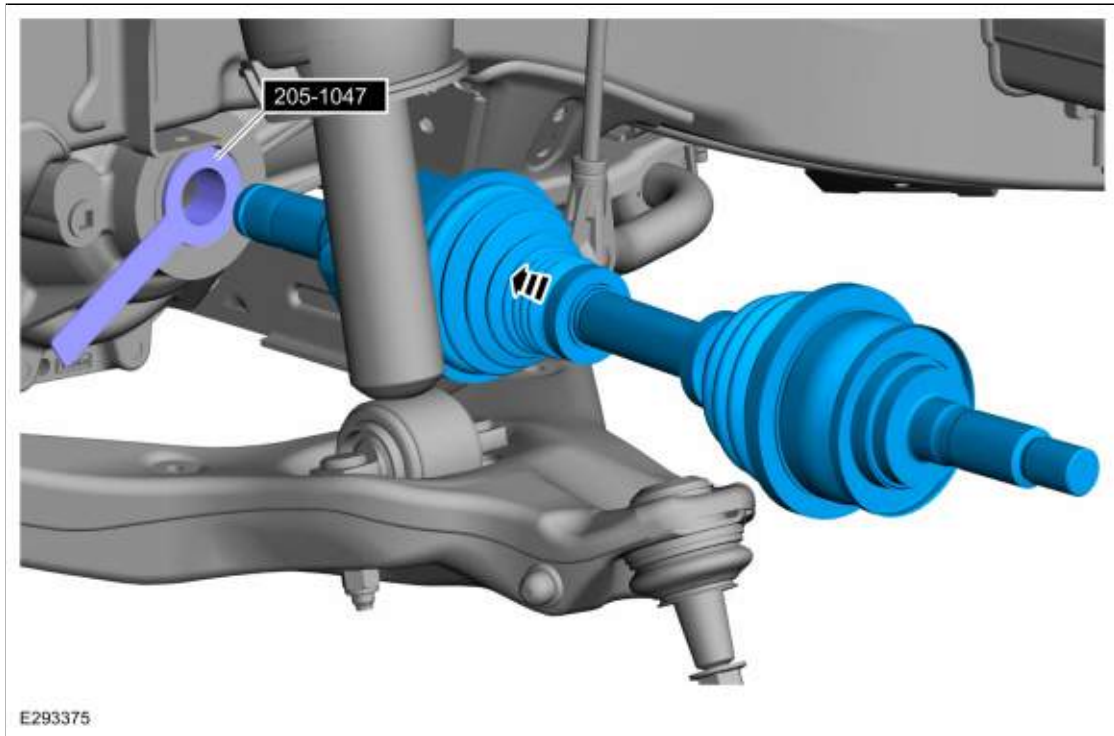

2. Install the wheel knuckle.
Refer to: [Wheel Knuckle](#) (204-01B Front Suspension - 4WD, Removal and Installation).
3. Fill the front differential.
Refer to: [Differential Draining and Filling](#) (205-03 Front Drive Axle/Differential, General Procedures).

Copyright © 2019 Ford Motor Company

Front Halfshaft RH

Removal

NOTICE: Do not hold the halfshaft by the CV joint.

NOTICE: The inner constant velocity (CV) joint must not be bent more than 18°.

NOTE: Take extra care not to damage the seal.

1. Drain the front differential.
Refer to: [Differential Draining and Filling](#) (205-03 Front Drive Axle/Differential, General Procedures).
2. Remove the wheel knuckle.
Refer to: [Wheel Knuckle](#) (204-01A Front Suspension - RWD, Removal and Installation).
3. **NOTE:** Do not pull on the halfshaft. Pull or pry on the inner CV (constant velocity) housing only or damage may occur.

Remove the front halfshaft RH. Remove and discard the circlip.

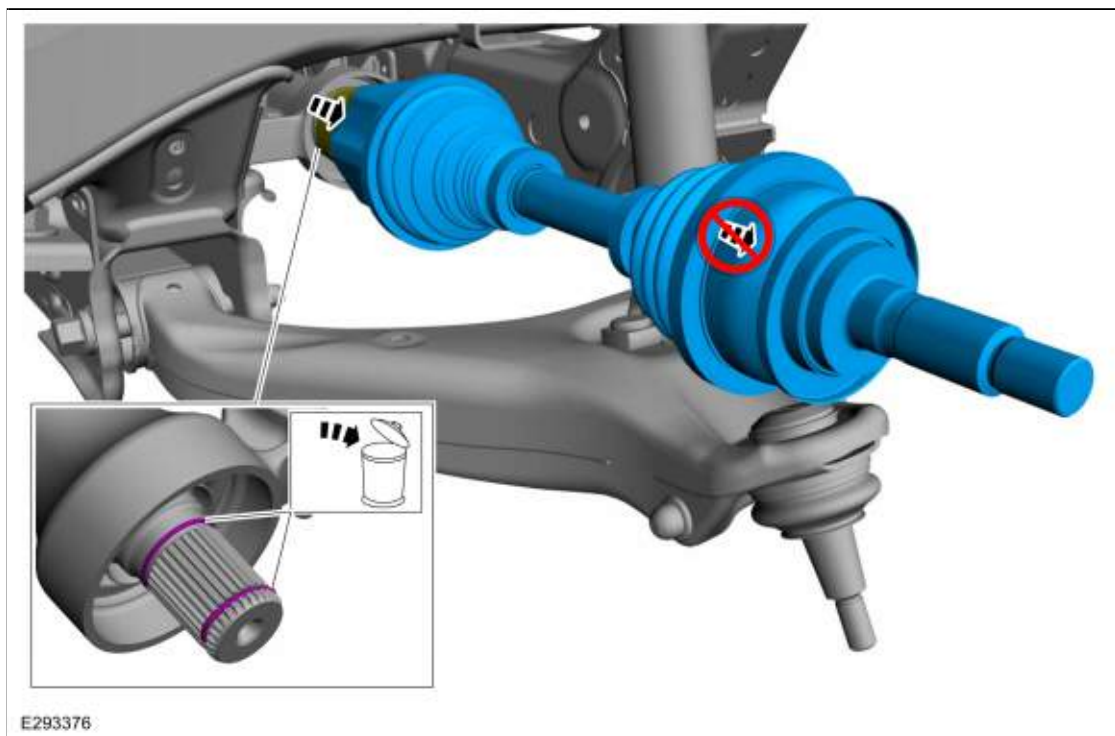

4.
 1. Clean the inner and outer halfshaft ends.
 2. Inspect the inner and outer halfshaft ends.

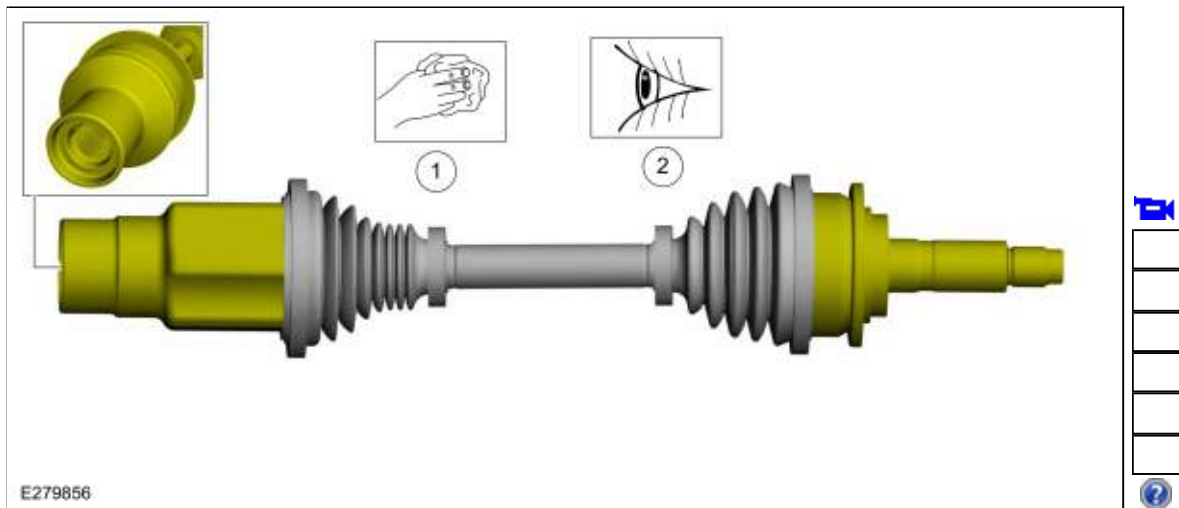

Installation

1. **NOTE:** Start one end of the retainer in the groove and work it over the halfshaft and into the groove to prevent the retainer from over expanding.

1. **NOTE:** Make sure that a new O-ring seal is installed.

NOTE: Make sure that a new O-ring seal is not twisted and it is completely seated in the groove.

Install the new front halfshaft RH O ring.

2. **NOTE:** Make sure that a new retaining clip is installed.

NOTE: Make sure that the retaining clip is fully seated in groove.

Install the new retaining clip.

3. **NOTE:** Insert shaft until circlip is fully seated. When checking if circlip is seated do not pull on outer CV joints, boot or on the shaft or damage can result.

NOTE: Pull on the inner CV joint to ensure the halfshaft circlip is seated properly.

Insert the halfshaft until the halfshaft retaining clip is fully seated.

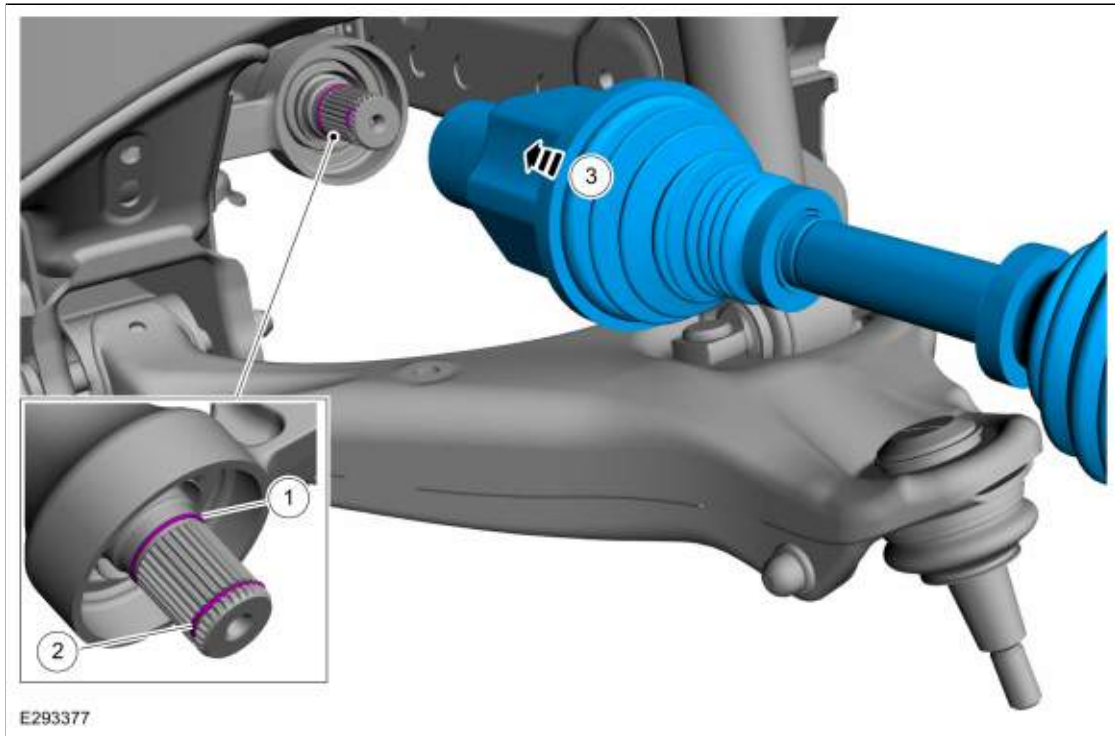

2. Install the wheel knuckle.
Refer to: [Wheel Knuckle](#) (204-01A Front Suspension - RWD, Removal and Installation).

Copyright © 2019 Ford Motor Company

