

INSTALLATION MANUAL

TAILGATE APPLIQUE
AD PART #: F026A24



**READ CAREFULLY
BEFORE INSTALLATION**



**WASH BEFORE
INSTALLING**

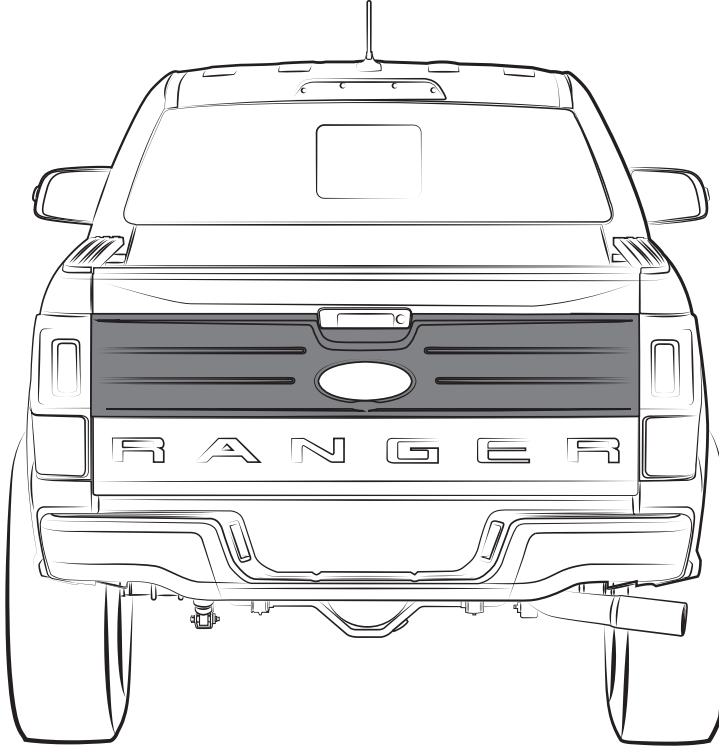

**WE RECOMMEND
2 PERSONS FOR
INSTALLATION**

AFTER INSTALLING

**DO NOT
WASH CAR**



24 hrs

**DRIVE SLOWLY
25 mph max**

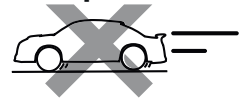



TOOLS



CHECK LIST

***Already pre-installed on the part**

ITEM	DESCRIPTION	DRAWING	AMOUNT
A	*VHB TAPE		INCLUDED IN ALL PARTS
B	ADHESION PROMOTER		1 PC

The ideal temperature range of the part and the vehicle when installing must be 16°C (60°F) to 40°C (104°F), this guarantees a correct assembly.

1 CLEAN

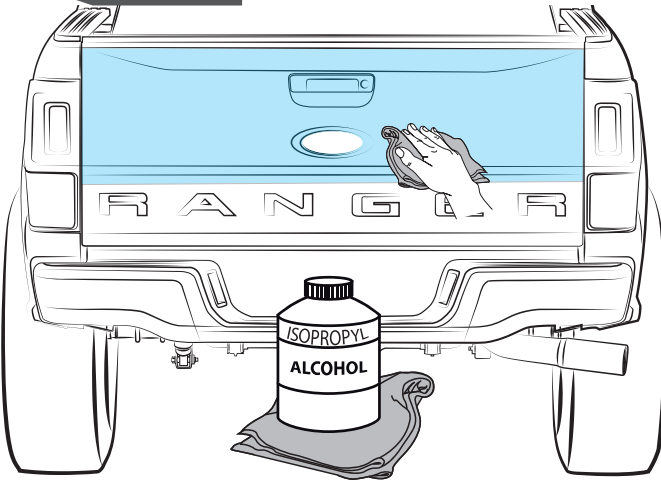

2 PRE-INSTALL

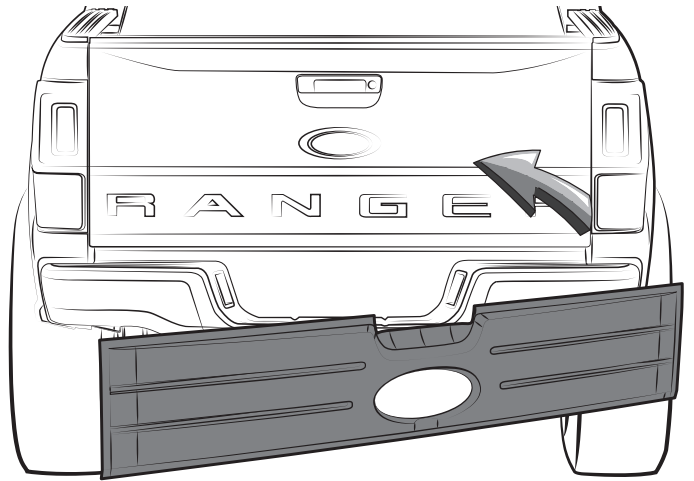

3 MARK

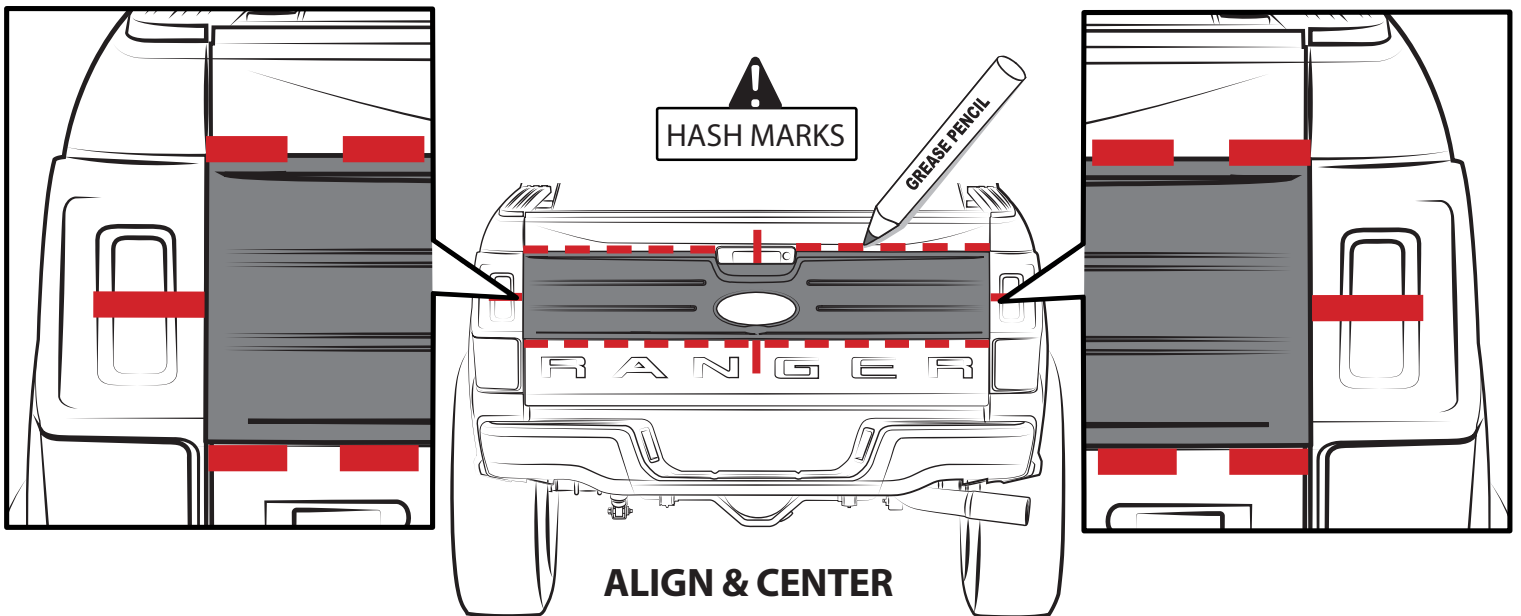

4 REMOVE

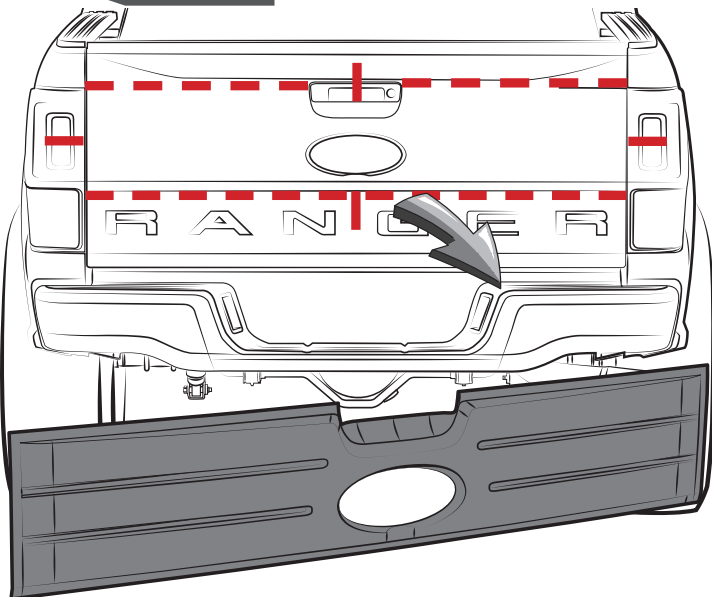

5 ADHESION PROMOTER

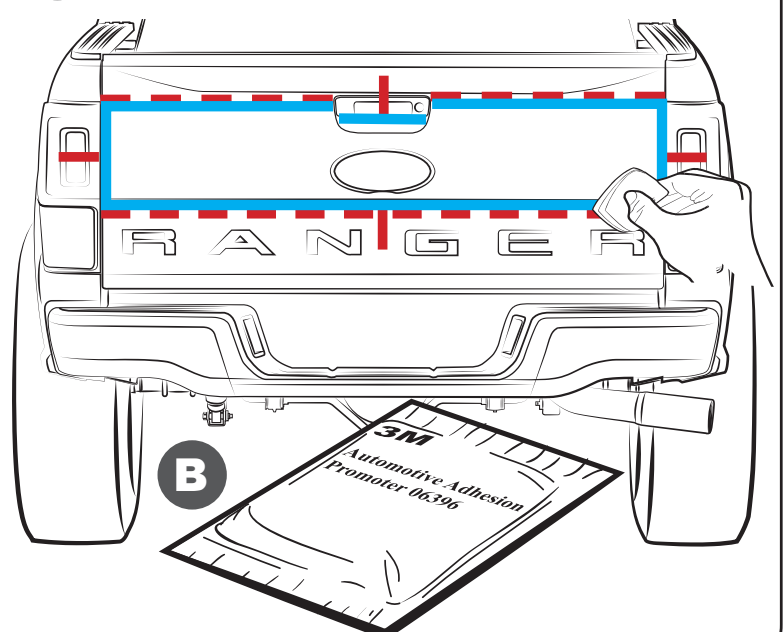

INSTALLATION MANUAL

6 PEEL

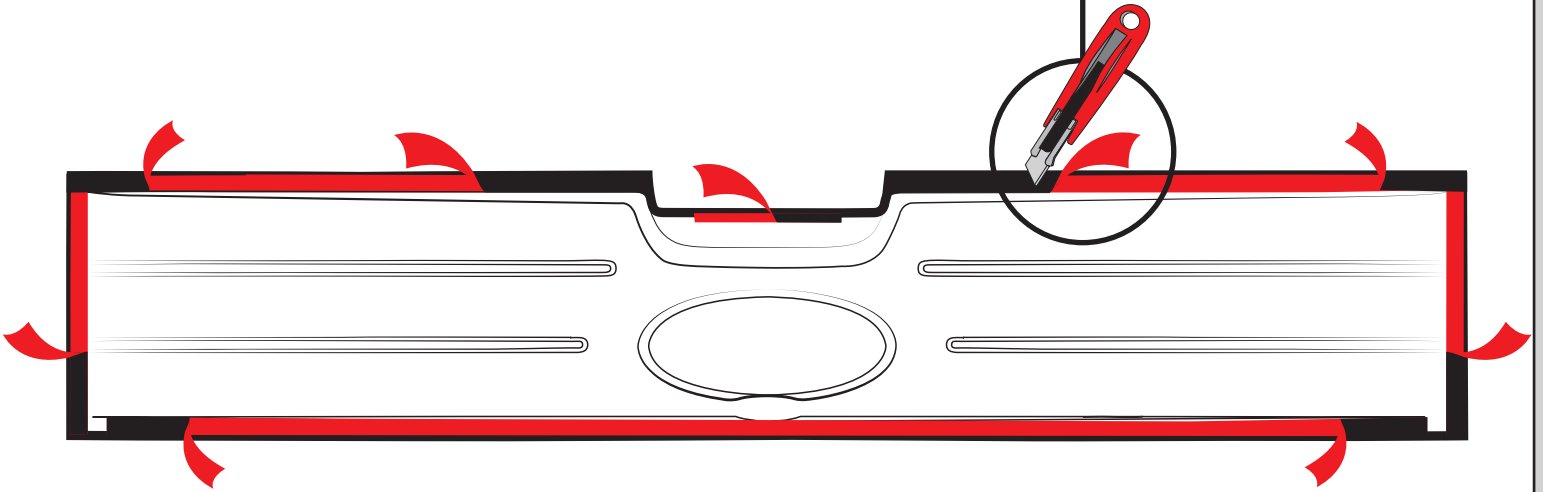
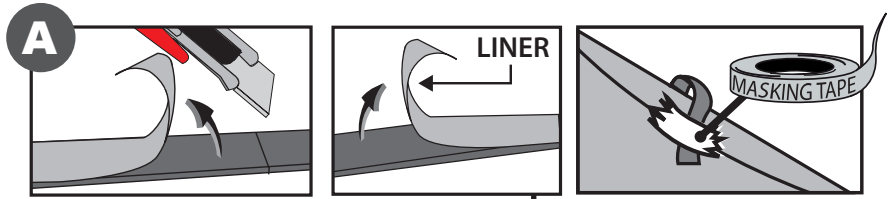

7 PLACE

ALIGN WITH MARKS

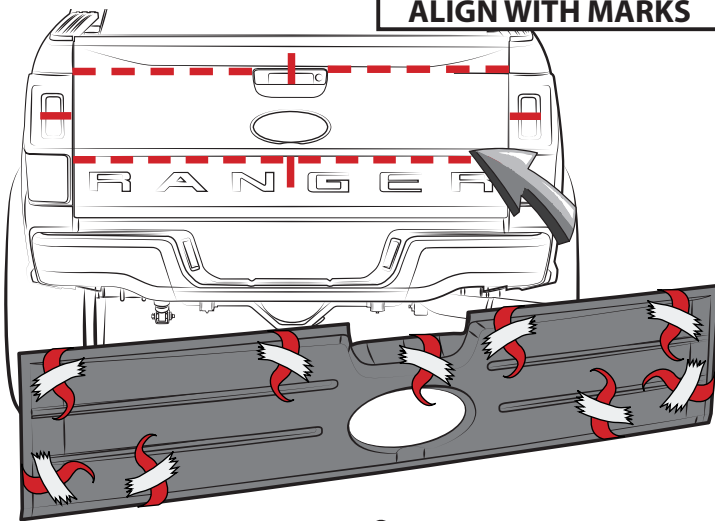

WARM SURFACES WITH HEAT GUN IF SURFACE TEMPERATURE IS TOO COLD.

8 REMOVE LINER

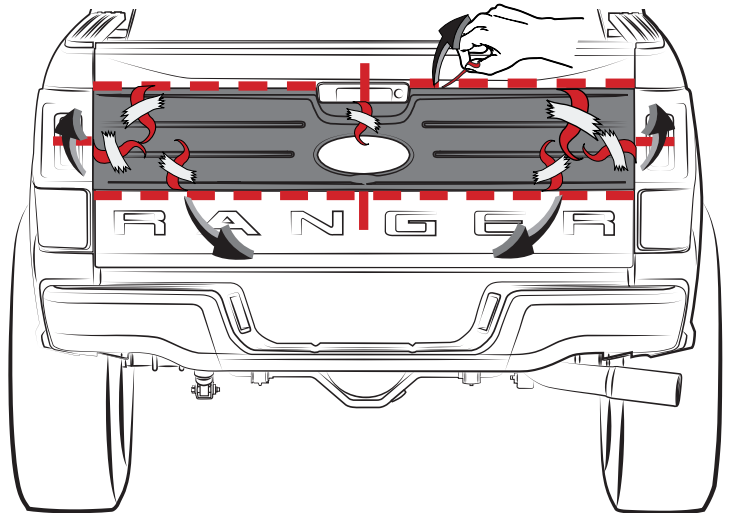

9 PRESS FIRMLY

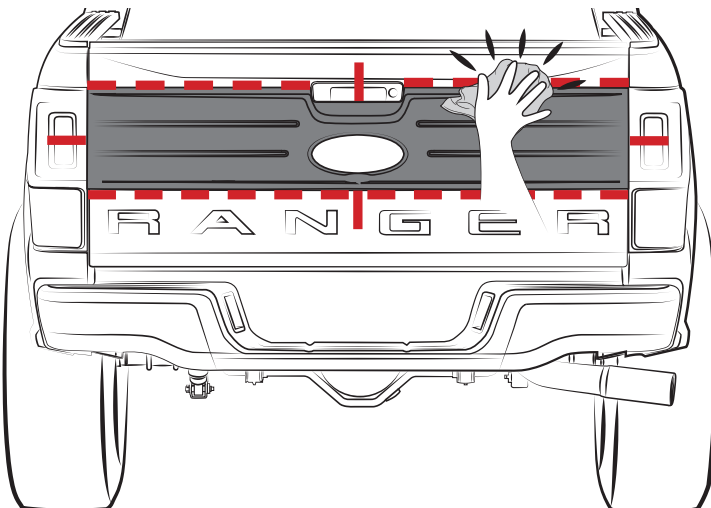

DURING APPLICATION, THE VEHICLE, ADD ON PARTS AND TAPE MUST BE AT OR ABOVE 16 °C OR 60 °F. A FULL SURFACE CONTACT BETWEEN TAPE AND SUBSTRATE IS IMPORTANT FOR GOOD ADHESION PERFORMANCE. CONTACT IS ACHIEVED BY APPLYING PRESSURE.

IN PRACTICE A PRESSURE BETWEEN 40 AND 50 N/CM² IS USUALLY NEEDED.

10 CLEAN OFF GREASE PENCIL MARK

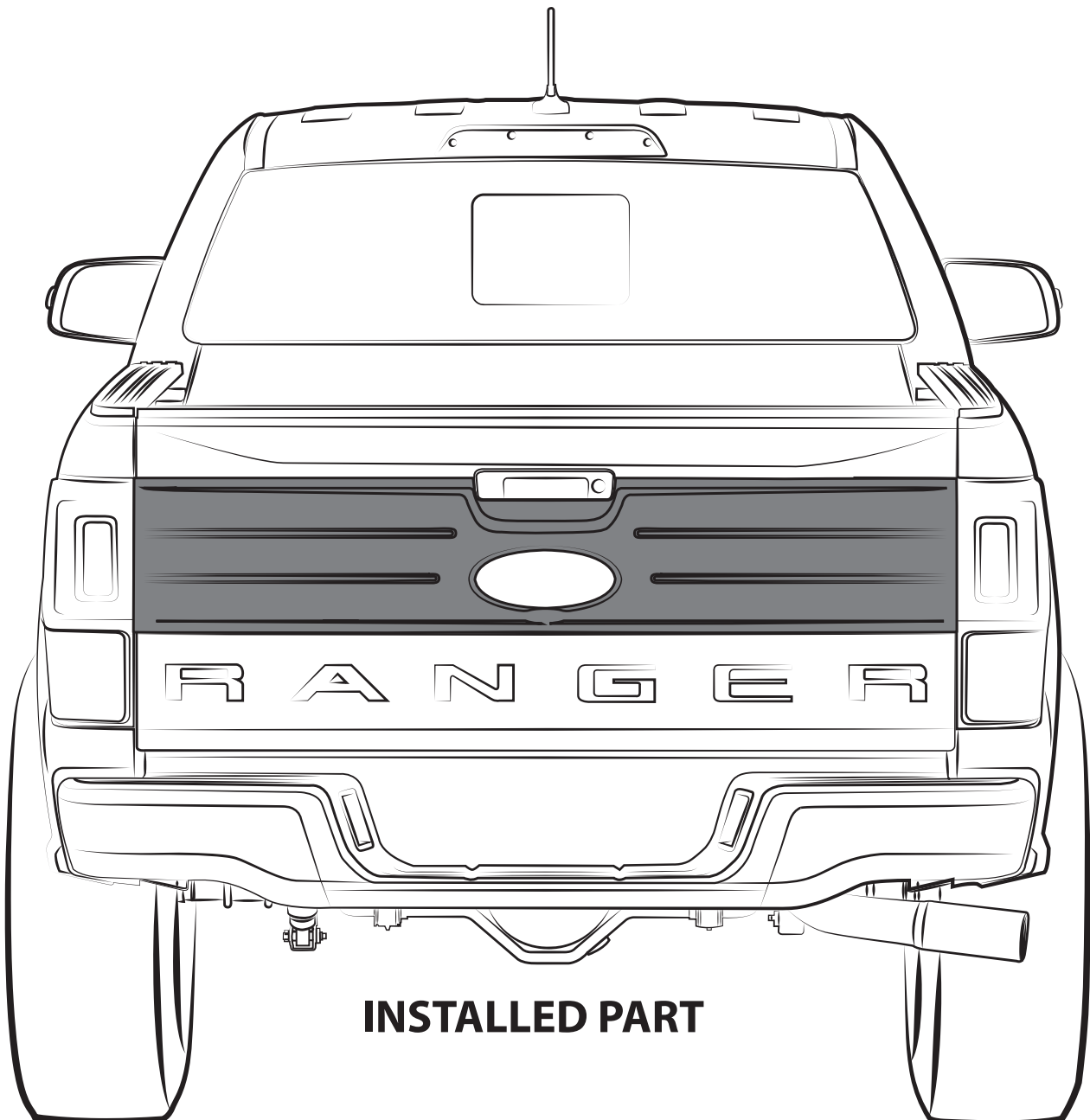
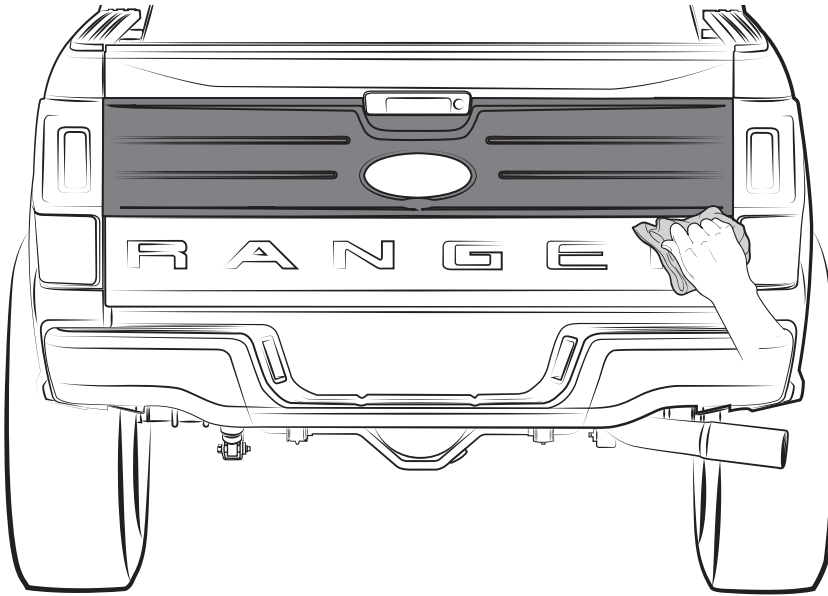

INSTALLED PART