

SYSTEM OPERATION AND COMPONENT DESCRIPTION

417-01 Exterior Lighting
Description and Operation

2020 Ranger

Exterior Lighting - System Operation and Component Description

System Operation

Headlamps

System Diagram

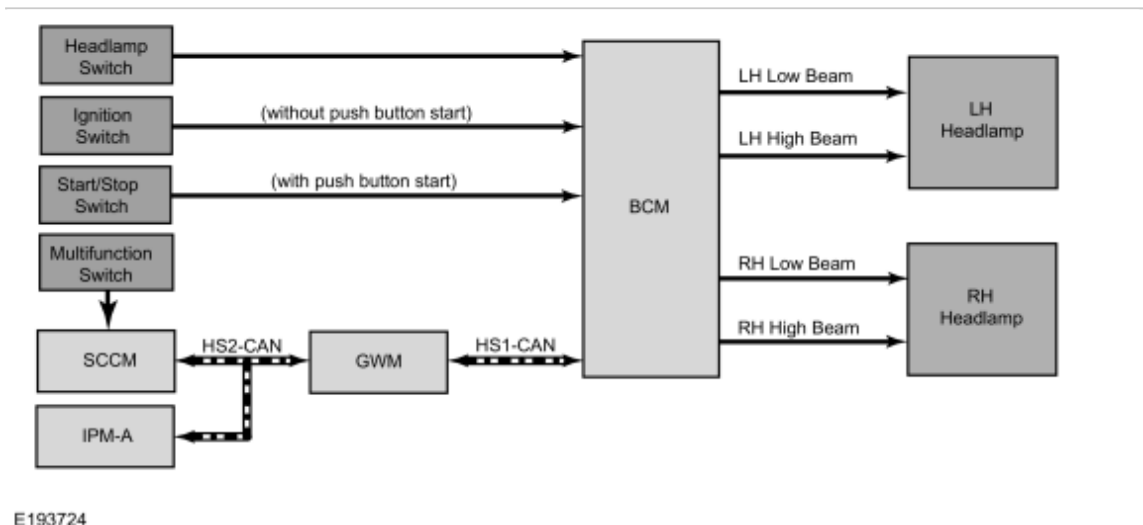

Network Message Chart

BCM Network Input Messages

Broadcast Message	Originating Module	Message Purpose
Headlamp flash to pass status	SCCM	Indicates to the BCM a request for the high beams or flash-to-pass.

Low Beams

The BCM monitors the headlamp switch position by sending voltage signals on multiple circuits to the headlamp switch. There is one circuit for each headlamp switch position. At any given time, one of the signal circuits is switched to ground to indicate the headlamp switch position.

The BCM turns the parking lamps and headlamps on when the ignition is in RUN and the BCM detects a fault from the headlamp switch or wiring. This is normal behavior of the BCM when a fault has been detected with the inputs from the headlamp switch.

When the BCM receives a message requesting the headlamps on, it supplies voltage to the low beam headlamp bulbs (halogen headlamps) or the headlamp Light Emitting Diodes (LEDs) (LED headlamps).

The BCM also provides Field Effect Transistor (FET) protection of the low beam output circuits. When an excessive current draw is detected, the BCM disables the affected circuit driver. For additional information on BCM Field Effect Transistor (FET) protection,

Refer to: Module Controlled Functions - System Operation and Component Description (419-10 Multifunction Electronic Modules, Description and Operation) .

High Beams

The SCCM monitors the LH steering column multifunction switch for a high beam request. When the LH steering column multifunction switch is in the HIGH BEAMS position, the SCCM sends a message over the HS-CAN2 to the GWM , then the GWM sends the message to the BCM over the HS-CAN1 .

For vehicles with halogen headlamps, when the low beams are on and the BCM receives a request for high beams, the low beam bulb remains powered on and the high beam bulb is also activated. This changes the headlamp beam pattern to illuminate a greater distance.

For vehicles with LED headlamps, when the low beams are on and the BCM receives a request for high beams, the shutter within each headlamp is activated. This changes the headlamp beam pattern to illuminate a greater distance.

The BCM also provides Field Effect Transistor (FET) protection of the high beam output circuits. When an excessive current draw is detected, the BCM disables the affected circuit driver. For additional information on BCM Field Effect Transistor (FET) protection,

Refer to: Module Controlled Functions - System Operation and Component Description (419-10 Multifunction Electronic Modules, Description and Operation) .

Flash-To-Pass

The SCCM monitors the LH steering column multifunction switch for a flash-to-pass request. When the LH steering column multifunction switch is in the FLASH-TO-PASS position, the SCCM sends a message over the HS-CAN2 to the GWM then the GWM sends the message to the BCM over the HS-CAN1 .

Headlamp Exit Delay

After you switch the ignition off, you can switch the headlamps on by pulling the direction indicator lever toward you. You will hear a short tone. The headlamps will switch off automatically after three minutes with any door open or 30 seconds after the last door has been closed. You can cancel this feature by pulling the direction indicator toward you again or switching the ignition on.

Headlamp Exit Delay

When the ignition is OFF and the LH multifunction switch is placed in the flash-to-pass position and released, the parking lamps and low beams are illuminated. They remain illuminated until:

- 3 minutes have elapsed with a door open.
- 30 seconds have elapsed after all doors are closed.
- the LH multifunction switch is placed in the flash-to-pass position again.
- the ignition switches to RUN.

Within the 30 second delay and all the doors closed, opening any door results in the 3 minute timer restarting.

DRL

System Diagram

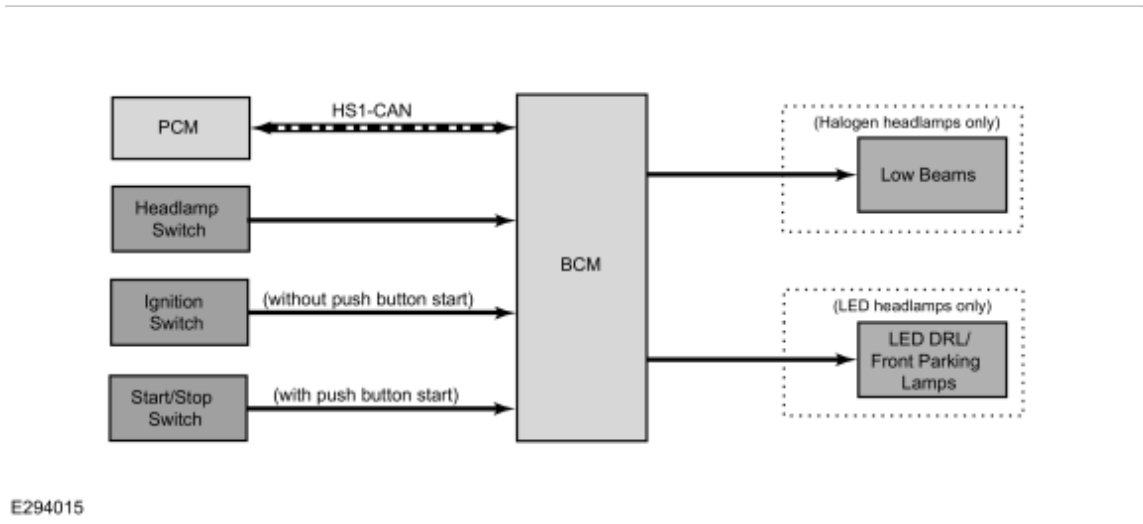

Network Message Chart

BCM Network Input Messages

Broadcast Message	Originating Module	Message Purpose
Gear position	PCM	Indicates the GSM request to the BCM . When the gear shifter has selected any position other than park, the BCM activates the DRL .

DRL

For halogen headlamps, the DRL system utilizes the existing circuitry and components from the headlamp low beam system illuminating the low beam bulb at a reduced intensity.

For vehicles equipped with LED headlamps, the DRL system illuminates the LED DRL /front parking lamps at full intensity in the headlamp assembly

When the ignition is in ON, the BCM supplies voltage to each headlamp assembly.

The BCM monitors the ignition status, the headlamp switch and autolamp status.

There are two types of DRL , conventional (where it is required) and configurable.

When equipped with conventional DRL , the DRL are active in any headlamp switch position except the HEADLAMPS position.

The conventional DRL are activated when the following conditions are met:

- the ignition is ON
- the headlamps switch is in OFF, PARKLAMPS or AUTOLAMPS position and the headlamps have not been turned on by the autolamp system.

- the transmission is not in PARK

When equipped with configurable DRL , the DRL may be enabled through the IPC message center. When enabled, the DRL are active only in the AUTOLAMPS headlamp position. When autolamps request the headlamps on, the DRL are de-activated.

The configurable DRL are activated when the following conditions are met:

- the ignition is ON.
- the headlamps switch is in AUTOLAMPS position and the headlamps have not been turned on by the autolamp system.
- the transmission is not in PARK.

When the transmission is in not in PARK, the PCM sends a message over the HS-CAN1 to the BCM indicating the transmission is not in PARK.

The BCM also provides Field Effect Transistor (FET) protection of the DRL output circuits. When an excessive current draw is detected, the BCM disables the affected circuit driver.

Refer to: Module Controlled Functions - System Operation and Component Description (419-10 Multifunction Electronic Modules, Description and Operation) .

Autolamps

System Diagram

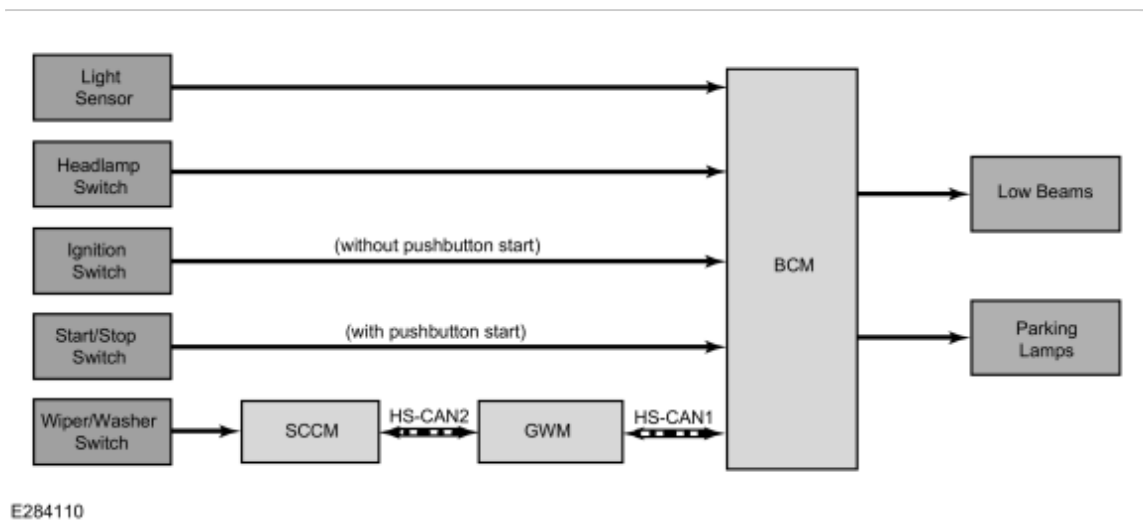

Network Message Chart

BCM Network Input Messages

Broadcast Message	Originating Module	Message Purpose
Front wiper status	SCCM	The BCM uses the wiper status information for the operation of the wiper activated headlamps feature.

Autolamps

The BCM monitors the light sensor. The light sensor input to the BCM varies with the ambient light conditions.

The BCM monitors the headlamp switch circuits to indicate the headlamp switch position.

When the BCM receives a headlamp switch status indicating a request for the autolamps, and the ambient lighting is low enough, the BCM illuminates the exterior parking and low beam lamps.

Headlamps On With Wipers On Function

When the headlamp switch is in the autolamps position, the exterior lamps turn on when the front wipers are in low or high. This feature does not activate the exterior lamps during a mist wipe, while the wipers are on to clear washer fluid during a wash condition or if the wipers are in automatic or intermittent modes.

The exterior lamps turn off when the ignition switches OFF, the headlamp switch is placed in the OFF position, or the front wipers are turned off. The exception to this is when the exterior lights are on because of darkness determined by the autolamp system.

Stoplamps

System Diagram

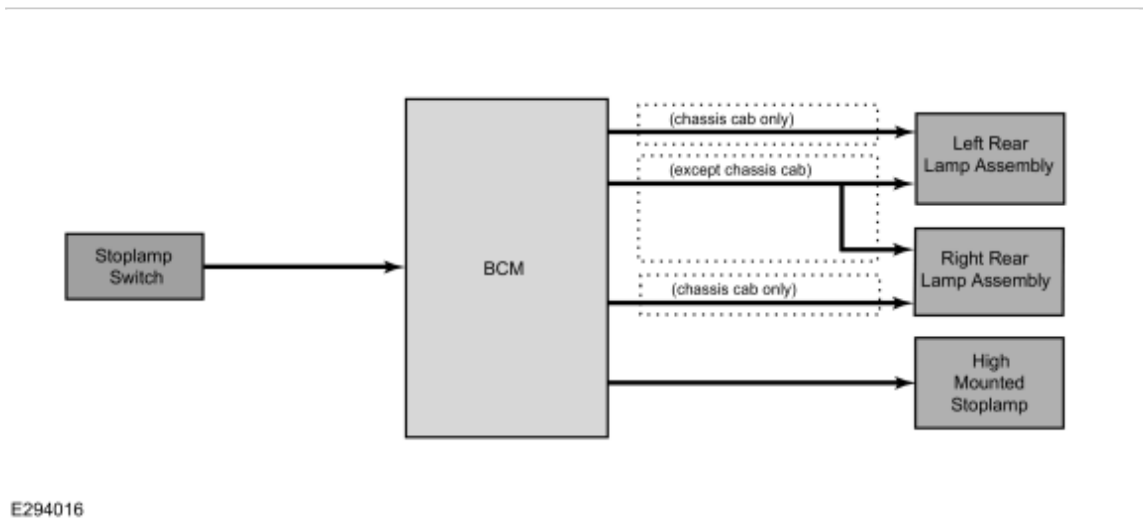

Stoplamps

The BCM monitors the input from the stoplamp switch. When the brake pedal is applied, voltage is routed to the BCM, indicating a request for the stoplamps. The BCM then supplies voltage to the stoplamps.

For vehicles except chassis cab, the BCM uses 2 separate output circuits. The LH stoplamp and RH stoplamp output circuit and high-mounted stoplamp output circuit.

For vehicles with chassis cab, the BCM uses 3 separate output circuits. The LH stop/turn lamp and RH stop/turn lamp output circuit and high-mounted stoplamp output circuit.

The BCM also provides Field Effect Transistor (FET) protection of the stoplamp output circuits. When an excessive current draw is detected, the BCM disables the affected stoplamp circuit driver.

Refer to: Module Controlled Functions - System Operation and Component Description (419-10 Multifunction Electronic Modules, Description and Operation).

Turn Signal and Hazard Lamps

System Diagram

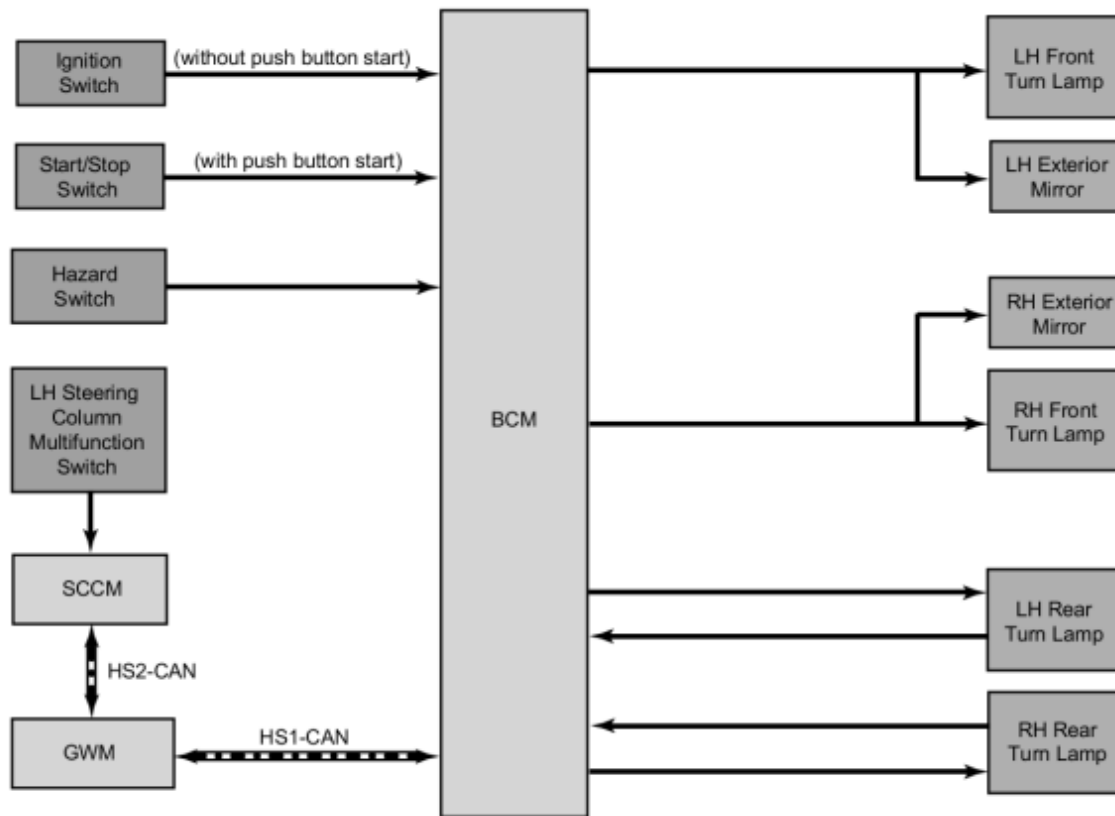

E294017

Network Message Chart

BCM Network Input Messages

Broadcast Message	Originating Module	Message Purpose
Turn signal switch status	SCCM	Indicates the turn signal stalk position on the LH steering column multifunction switch (left/right lane change or turn signal on or off). The BCM activates the left/right turn signals based on this input.

DDM and PDM Network Input Messages

Broadcast Message	Originating Module	Message Purpose
Turn indication request	BCM	A command to the DDM or PDM to activate/deactivate the exterior mirror turn indicator.

Turn Signals

The SCCM monitors the LH steering column multifunction switch position. When the LH steering column multifunction switch is in the LH TURN or RH TURN position, the SCCM sends a message over the HS-CAN2 to the GWM then the GWM sends the message to the BCM over the HS-CAN1 indicating a request for the LH or RH turn signal.

When the BCM receives a request for a turn signal, the BCM supplies on/off voltage to the appropriate turn lamps.

If a front or rear turn signal lamp is inoperative, the IPC turn lamp indicator fast flashes at approximately 150 times per minute to indicate a bulb outage to the driver (the exterior turn lamps will still flash at approximately 70 times per minute).

The BCM also provides Field Effect Transistor (FET) protection of the turn lamp output circuits. When an excessive current draw is detected, the BCM disables the affected turn lamp circuit driver.

Refer to: Module Controlled Functions - System Operation and Component Description (419-10 Multifunction Electronic Modules, Description and Operation) .

Hazard Lamps

The BCM sends a voltage signal to the hazard flasher lamp switch to monitor for a hazard lamp function request. When the hazard flasher lamp switch is pressed, the voltage signal is routed to ground, indicating a request to activate or deactivate the hazard lamp function.

When the BCM receives a request for the hazard lamps, the BCM supplies on/off voltage to the front and rear turn lamps and sends a request to the door modules to flash the exterior mirror turn lamps.

Parking, Rear, and License Plate Lamps

System Diagram

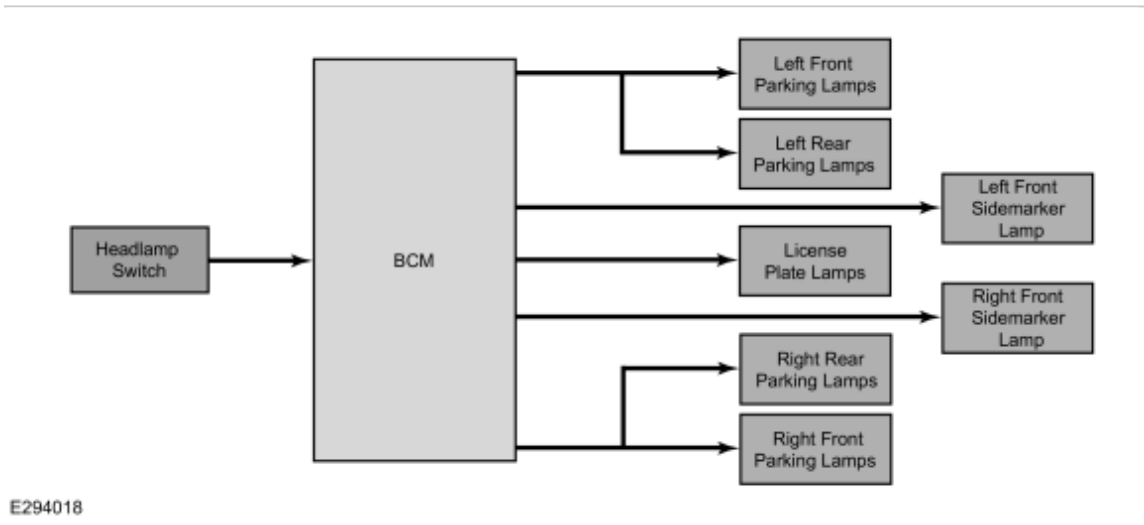

Parking Lamps

The BCM monitors the headlamp switch position by sending voltage signals on multiple circuits to the headlamp switch. There is one circuit for each headlamp switch position. At any given time, one of the signal circuits is switched to ground to indicate the headlamp switch position.

If the BCM detects a fault from the headlamp switch or loses communication with the headlamp switch, the BCM turns the parking and headlamps on. This is normal behavior of the BCM when a fault has been detected with the inputs from the headlamp switch.

When the BCM receives a request for a parking lamps, the BCM supplies voltage to the headlamp assembly, rear parking lamps and license plate lamps.

The BCM also provides Field Effect Transistor (FET) protection of the parking lamps output circuits. When an excessive current draw is detected, the BCM disables the affected parking lamps circuit driver.

Refer to: Module Controlled Functions - System Operation and Component Description (419-10 Multifunction Electronic Modules, Description and Operation) .

Fog Lamps

System Diagram

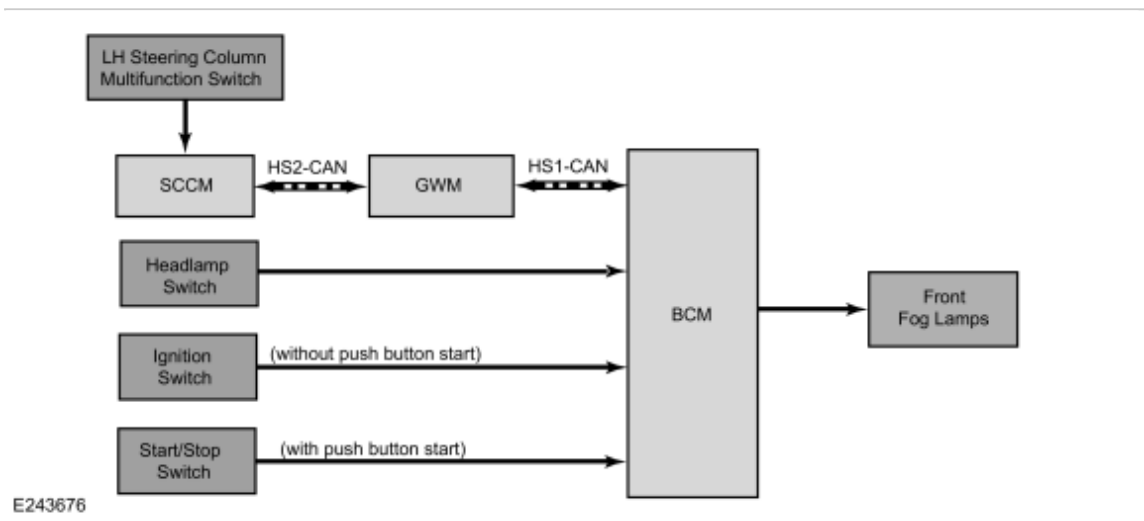

Network Message Chart

BCM Network Input Messages

Broadcast Message	Originating Module	Message Purpose
Headlamp flash to pass status	SCCM	Indicates to the BCM a request for the high beams or flash-to-pass.

Fog Lamps

The BCM monitors the headlamp switch position by sending voltage signals on multiple circuits to the headlamp switch. There is one circuit for each headlamp switch position. At any given time, one of the signal circuits is switched to ground to indicate the headlamp switch position.

When the BCM receives input from the headlamp switch indicating a request for the front fog lamps, the BCM provides voltage to the front fog lamps.

The BCM also provides an Field Effect Transistor (FET) protection of the fog lamp output circuits. When an excessive current draw is detected, the BCM disables the fog lamp output circuit drivers.

Refer to: Module Controlled Functions - System Operation and Component Description (419-10 Multifunction Electronic Modules, Description and Operation) .

Reversing Lamps

System Diagram

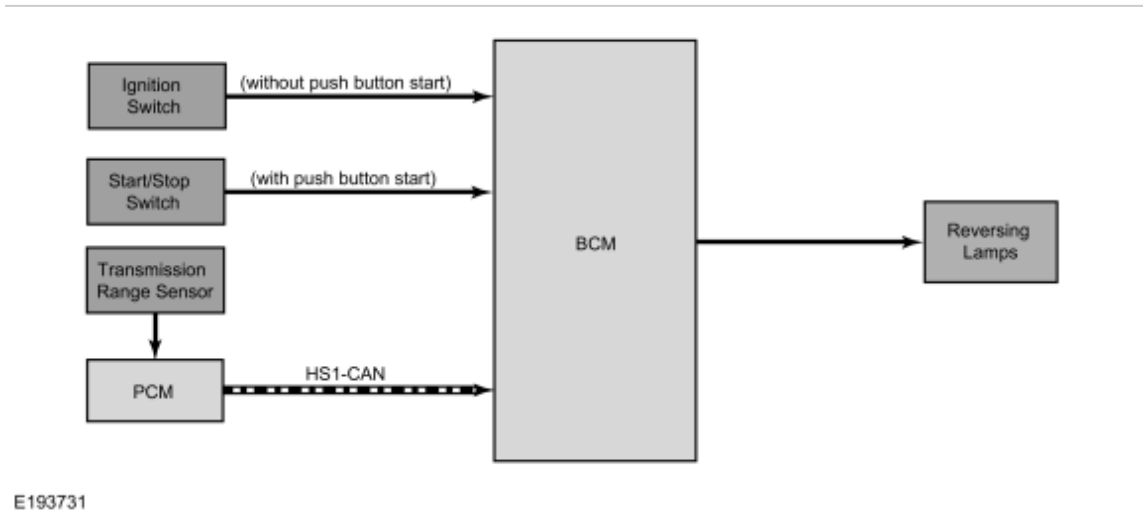

Network Message Chart

BCM Network Input Messages

Broadcast Message	Originating Module	Message Purpose

Broadcast Message	Originating Module	Message Purpose
Reverse	PCM	Indicates the transmission is in reverse gear to the BCM . When the transmission is in REVERSE and the ignition in RUN, the BCM provides voltage to the reversing lamps.

Reversing Lamps

When the transmission is in REVERSE, the PCM sends a message over the HS-CAN to the BCM indicating the transmission is in REVERSE. The BCM provides voltage to the reversing lamp when it receives the message that the transmission is in REVERSE and the ignition is in RUN.

The BCM also provides Field Effect Transistor (FET) protection of the reversing lamp output circuit. When an excessive current draw is detected, the BCM disables the affected reversing lamps circuit driver.

Refer to: Module Controlled Functions - System Operation and Component Description (419-10 Multifunction Electronic Modules, Description and Operation) .

Trailer Lamps - Without TRM

System Diagram

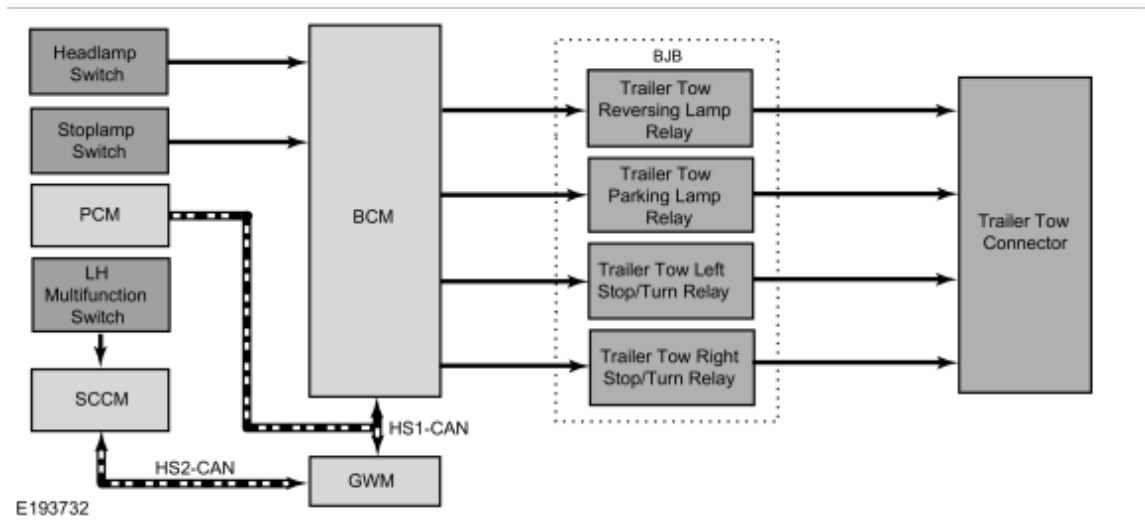

Network Message Chart

BCM Network Input Messages

Broadcast Message	Originating Module	Message Purpose
Gear position	PCM	Indicates the transmission is in reverse gear to the BCM . When the transmission is in REVERSE and the ignition in RUN, the BCM provides voltage to the reversing lamps.

Broadcast Message	Originating Module	Message Purpose
Turn signal switch status	SCCM	Indicates the turn signal stalk position on the LH steering column multifunction switch (left/right lane change or turn signal on or off). The BCM activates the left/right turn signals based on this input.

Trailer Stop-Turn Lamps

The SCCM monitors the LH steering column multifunction switch position. When the LH steering column multifunction switch is in the left or right turn position, the SCCM sends a message over the HS-CAN2 to the GWM then the GWM sends the message to the BCM over the HS-CAN1 indicating a request for the LH or RH turn signal.

When the BCM receives a request for a turn signal, the BCM provides a switched ground path to the LH or RH stop/turn trailer tow relay (integral to the BJB). When the BCM provides ground the LH or RH stop/turn trailer tow relay, the relay is energized and the relay provides turn lamp voltage to the trailer tow connector.

When the BCM receives input from the stoplamp switch indicating that the brake pedal is being pressed, the BCM provides a ground path to the LH and RH stop/turn trailer tow relay (integral to the BJB). When the BCM provides ground the LH and RH stop/turn trailer tow relay, the relay is energized and the relay provides stop lamp voltage to the trailer tow connector.

Trailer Parking Lamps

The BCM monitors the headlamp switch position by sending voltage signals on multiple circuits to the headlamp switch. There is one circuit for each headlamp switch position. At any given time, one of the signal circuits is switched to ground to indicate the headlamp switch position.

When the parking lamps or headlamps position is selected, the BCM provides a ground path to the parking lamps trailer tow relay. When the BCM provides ground the parking lamps trailer tow relay, the relay is energized and the relay provides parking lamp voltage to the trailer tow connector.

Trailer Reversing Lamps

When the transmission is in REVERSE, the PCM sends a message over the HS-CAN1 to the BCM indicating the transmission is in REVERSE. The BCM provides ground to the reversing lamps trailer tow relay (integral to the BJB) when it receives the message that the transmission is in REVERSE and the ignition is in RUN. When the BCM provides ground the reversing lamps trailer tow relay, the relay is energized and the relay provides reversing lamp voltage to the trailer tow connector.

Trailer Lamps - With TRM

System Diagram

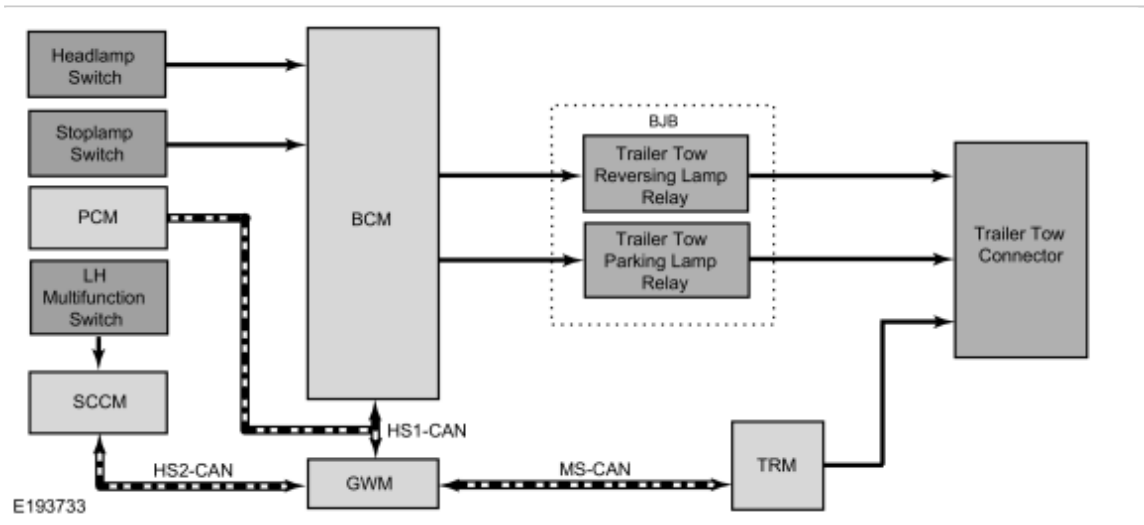

Network Message Chart

BCM Network Input Messages

Broadcast Message	Originating Module	Message Purpose
Gear position	PCM	Indicates the transmission is in reverse gear to the BCM . When the transmission is in REVERSE and the ignition in RUN, the BCM provides voltage to the reversing lamps.
Turn signal switch status	SCCM	Indicates the turn signal stalk position on the LH steering column multifunction switch (left/right lane change or turn signal on or off).

TRM Network Input Messages

Broadcast Message	Originating Module	Message Purpose
Turn indication request	BCM	A command to the TRM to activate/deactivate the turn indicator output to the trailer tow connector.
Stoplamp request	BCM	A command to the TRM to activate/deactivate the stop lamps output to the trailer tow connector.

Trailer Stop-Turn Lamps

The SCCM monitors the LH steering column multifunction switch position. When the LH steering column multifunction switch is in the left or right turn position, the SCCM sends a message over the HS-CAN2 to the GWM then the GWM sends the message to the BCM over the HS-CAN1 indicating a request for the LH or RH turn signal.

When the BCM receives a request for a turn signal, the BCM sends a turn indicator command message over the MS-CAN to the TRM to activate the requested stop/turn indicator output to the trailer tow connector.

When the BCM receives input from the stoplamp switch indicating that the brake pedal is being pressed, the TRM receives a stoplamp activation message over the MS-CAN to activate the requested stop/turn indicator output to the trailer tow connector.

Trailer Parking Lamps

The BCM monitors the headlamp switch position by sending voltage signals on multiple circuits to the headlamp switch. There is one circuit for each headlamp switch position. At any given time, one of the signal circuits is switched to ground to indicate the headlamp switch position.

When the parking lamps or headlamps position is selected, the BCM provides a ground path to the BJB parking lamps trailer tow relay (replaceable). When the BCM provides ground the parking lamps trailer tow relay, the relay is energized and the relay provides parking lamp voltage to the trailer tow connector.

Trailer Reversing Lamps

When the transmission is in REVERSE, the PCM sends a message over the HS-CAN1 to the BCM indicating the transmission is in REVERSE. The BCM provides ground to the BJB lamps trailer tow relay (non-replaceable) when it receives the message that the transmission is in REVERSE and the ignition is in RUN. When the BCM provides ground the reversing lamps trailer tow relay, the relay is energized and the relay provides reversing lamp voltage to the trailer tow connector.

Trailer Battery Charging

The TRM provides voltage to the trailer tow connector for trailer battery charging when all the Following are true:

- the TRM detects that a trailer is connected
- the ignition is on and engine is running
- a brake pedal application has been detected in the present ignition cycle
- the BCM load shed strategy is not active (a message will be displayed in the instrument cluster, such as "Low Battery Features Temporarily Turned Off" or "Turn Power Off To Save Battery", to indicate that BCM load shed strategy is active)

The TRM directly (no relay) supplies fuse protected voltage for trailer battery charging.

Field Effect Transistor (FET) Protection

The TRM utilizes a Field Effect Transistor (FET) protective circuit strategy for its lamp output circuits. Output loads (current level) are monitored for excessive current (typically short circuits) and are shut down (turns off the voltage or ground provided by the module) when a fault event is detected.

A Field Effect Transistor (FET) is a type of transistor that the control module software uses to control and monitor current flow on module outputs. The Field Effect Transistor (FET) protection strategy prevents module damage in the event of excessive current flow.

Output loads (current level) are monitored for excessive current draw (typically short circuits). When a fault event is detected the Field Effect Transistor (FET) turns off and a short circuit DTC sets. The module resets the Field Effect Transistor (FET) protection and allows the circuit to function when the fault is corrected or the ignition state is cycled off and then back on.

When the excessive circuit load occurs often enough, the module shuts down the output until a repair procedure is carried out. Each Field Effect Transistor (FET) protected circuit has 3 predefined levels of short circuit tolerance based on a module lifetime level of fault events based upon the durability of the Field Effect Transistor (FET).

When each level is reached, the DTC associated with the short circuit sets along with DTC U1000:00. These Diagnostic Trouble Codes (DTCs) can be cleared using the module on-demand self-test, then the Clear DTC operation on the scan tool (if the on-demand test shows the fault corrected). The module never resets the fault event counter to zero and continues to advance the fault event counter as short circuit fault events occur.

If the number of short circuit fault events reach the third level, then Diagnostic Trouble Codes (DTCs) U1000:00 and U3000:49 set along with the associated short circuit DTC . DTC **U3000:49 cannot be cleared** and the module **must be replaced** after the repair.

Component Description

Headlamp Assembly

The headlamps utilize a non-serviceable module (integrated into the headlamp assembly) that is used to control the headlamp daytime running/park/turn lamps.

Exterior lamps are vented to accommodate normal changes in pressure. Condensation can be a natural by-product of this design. When moist air enters the lamp assembly through the vents, there is a possibility that condensation can occur if the temperature is cold. When normal condensation occurs, a thin mist forms on the interior of the lens. The thin mist eventually clears and exits through the vents during normal operation. The amount of time it takes to clear the lens of acceptable mist varies with ambient humidity and lamp types. Normal condensation clears from any lamp in 48 hours under dry conditions.

Do not replace a lamp assembly with acceptable levels of condensation such as:

- presence of thin mist (no streaks, drip marks or droplets are present)
- fine mist covers less than 50% of the lens

Examples of unacceptable moisture (usually caused by a lamp housing leak):

- water puddling inside the lamp
- large water droplets, drip marks or streaks present on the interior of the lens

Headlamp Switch

The headlamp switch sends a headlamp switch status message over the LIN to the BCM to indicate the headlamp switch status (position or a fault with the headlamp switch).

Light Sensor

The BCM sends a voltage signal to the light sensor. The light sensor provides resistance between the voltage signal and ground. The resistance varies depending on the amount of ambient light detected by the light sensor. The brighter the ambient light, the lower the resistance. By varying the resistance, the BCM can determine the amount of ambient light.

Stoplamp Switch

The stoplamp switch is a normally open switch and is provided voltage at all times. When the brake pedal is applied, the switch closes and routes voltage to the BCM .
